

Q1.The word equation shows the reaction between anhydrous cobalt chloride and water.

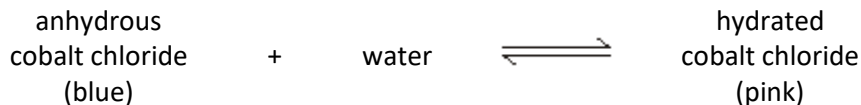

(a) Name the type of reaction shown by the sign \rightleftharpoons

.....

(1)

(b) When the student added water to anhydrous cobalt chloride what happened?

.....

(1)

(c) A student measured the temperature rise when anhydrous cobalt chloride was added to water.

The student's results are shown in the table below.

	Trial 1	Trial 2	Trial 3
Temperature rise in °C	8.5	8.2	8.2

Calculate the mean temperature rise.

.....

Temperature = °C

(1)

(d) When water was added to anhydrous cobalt chloride an exothermic reaction took place.

Name the type of reaction when hydrated cobalt chloride reacts to form anhydrous cobalt chloride and water.

.....

.....

(1)
(Total 4 marks)

Q2.A flow diagram of the Haber process is shown below.

The Haber process produces ammonia from nitrogen and hydrogen.

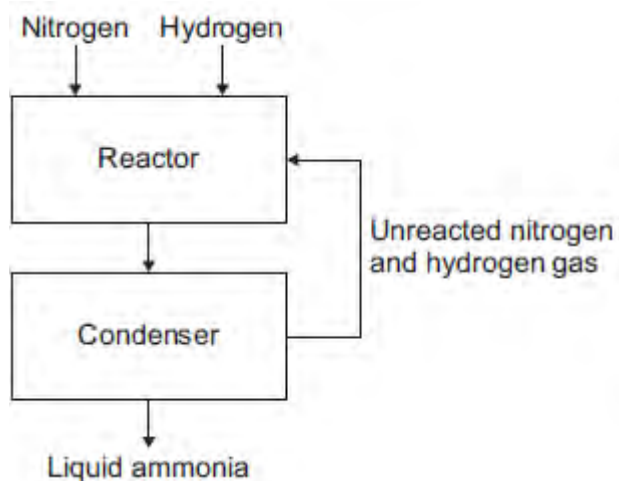

(a) Use the correct answer from the box to complete the sentence.

air	limestone	natural gas
-----	-----------	-------------

Hydrogen is obtained from

(1)

(b) In the reactor, nitrogen and hydrogen at a high pressure are heated and passed over a catalyst.

(i) Use the correct answer from the box to complete the sentence.

25	100	450
----	-----	-----

The temperature in the reactor is °C

(1)

(ii) Use the correct answer from the box to complete the sentence.

copper	iron	nickel
--------	------	--------

The catalyst used in the reactor is

(1)

(iii) How does a catalyst speed up a reaction?

Tick (✓) **one** box.

The catalyst lowers the activation energy.

The catalyst gives the reactants extra energy.

The catalyst increases the pressure in the reactor.

(1)

(c) A mixture of gases leaves the reactor.

The mixture contains ammonia, nitrogen and hydrogen.

Describe what happens to this mixture of gases in the condenser.

Use the flow diagram to help you.

.....

.....

.....

.....

.....

.....

(3)

(Total 7 marks)

Q3. Read the information and then answer the questions.

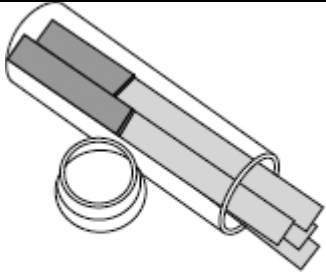

COBALT CHLORIDE PAPER

Cobalt chloride paper can be used to test for water.

The paper contains anhydrous cobalt chloride.

The jar containing the papers must be kept closed when not being used.

The equation shows the reaction between anhydrous cobalt chloride and water.

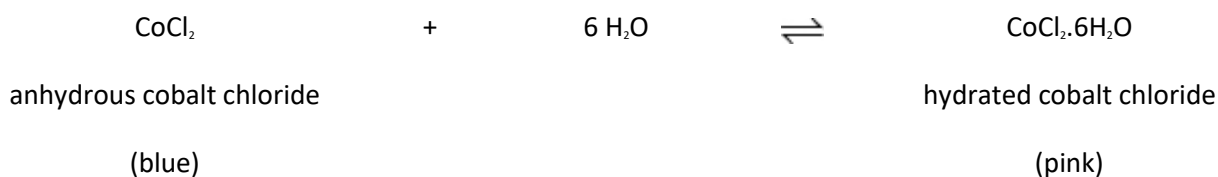

(a) Choose **one** word from the box to complete the sentence.

endothermic	exothermic	reversible
--------------------	-------------------	-------------------

The symbol \rightleftharpoons means that the reaction is

(1)

(b) Describe the colour change when water is added to the cobalt chloride paper.

.....

.....

(1)

(c) Suggest why the jar containing the unused cobalt chloride papers must be kept closed.

.....
.....

(1)
(Total 3 marks)

Q4. (a) Ammonia solution is used in cleaning products to remove grease from kitchen surfaces.



Ammonia solution is alkaline.

(i) Draw a ring around the number most likely to be the pH of ammonia solution.

1 **3** **7** **10**

(1)

(ii) Draw a ring around the ion in ammonia solution which makes it alkaline.

Cl⁻ **H⁺** **Na⁺** **OH⁻**

(1)

(b) Ammonia is made using the Haber process.

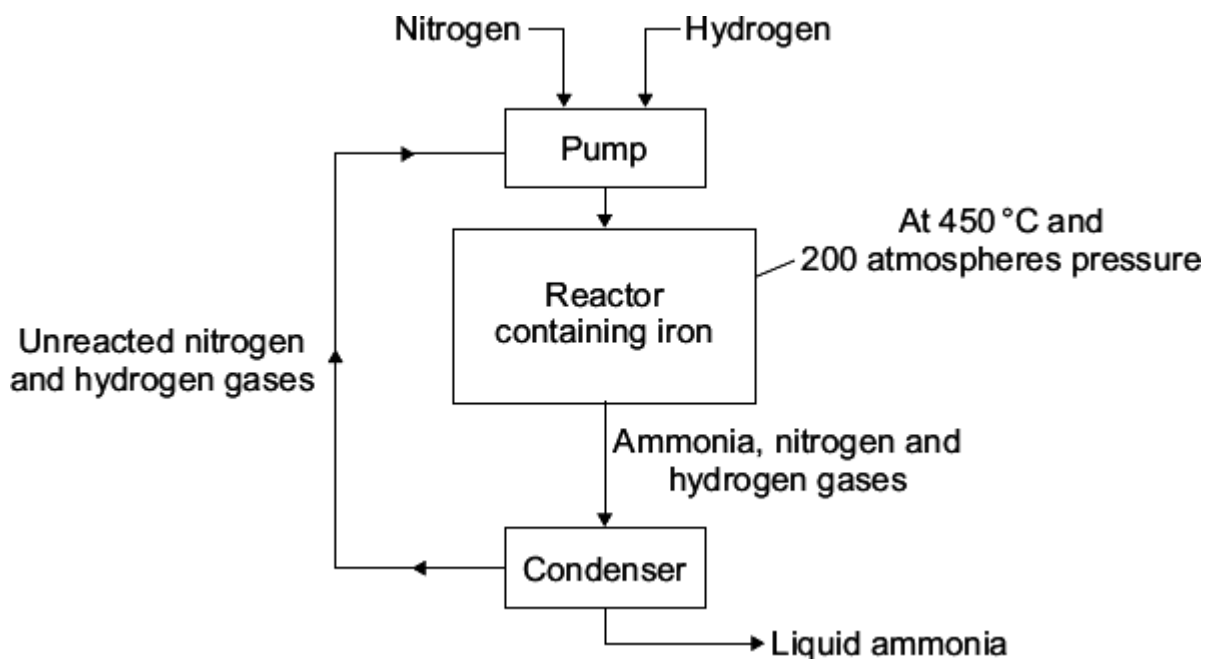

(i) Where does the nitrogen used in the Haber process come from?

Draw a ring around your answer.

air **natural gas** **water**

(1)

(ii) A high temperature of 450 °C is used in the reactor.

Tick (✓) **two** reasons in the table which explain why high temperatures make reactions faster.

Reasons	Tick (✓)
Particles move faster	
Particles are closer together	
Particles collide more often	
Particles have less energy	

(2)

(iii) The iron in the reactor speeds up the reaction but is not used up.

What is the name given to substances that speed up the chemical reaction but which are not used up during the reaction?

.....

(1)

(c) Complete the sentence.

The condenser separates the ammonia from the unreacted nitrogen and hydrogen by turning the ammonia into a

(1)

(Total 7 marks)

Q5. Hand warmers use chemical reactions.



(a) The table shows temperature changes for chemical reactions **A**, **B** and **C**.

Reaction	Starting temperature in °C	Final temperature in °C	Change in temperature in °C
A	18	25	+ 7
B	17	+ 5
C	18	27	+ 9

What is the final temperature for reaction **B**? Write your answer in the table.

(1)

(b) (i) What name is given to reactions that heat the surroundings?

(1)

(ii) Which reaction, **A**, **B** or **C**, would be best to use in a hand warmer?

Reaction

Give a reason why you chose this reaction.

.....
.....

(2)

(c) A student added water to some anhydrous copper sulfate.

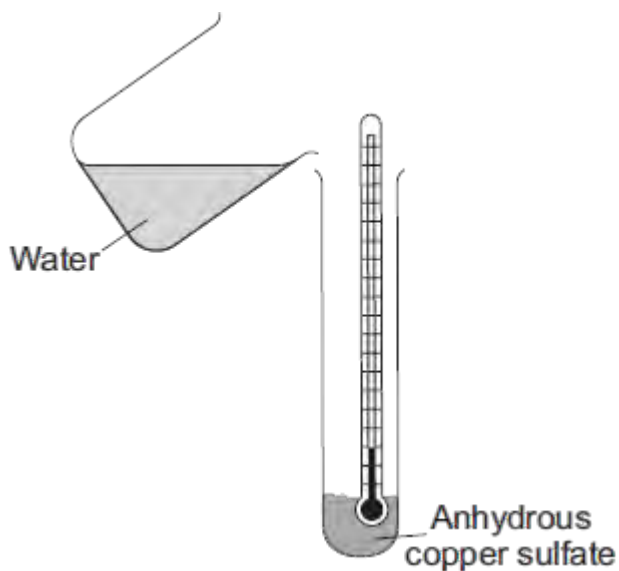

The equation for the reaction is shown.

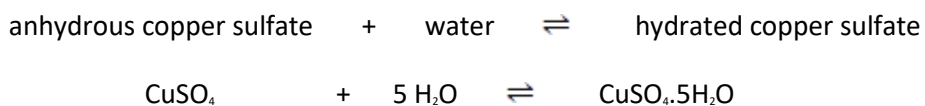

The student measured the temperature before and after the reaction.

(i) The measurements showed that this reaction can be used for a hand warmer.

Draw a ring around the correct answer to complete the sentence.

When water is added to anhydrous copper sulfate the temperature

of the mixture

increases.

decreases.

stays the same.

(1)

(ii) Anhydrous copper sulfate is white.

What colour is seen after water is added to the anhydrous copper sulfate?

.....

(1)

(iii) What does the symbol \rightleftharpoons mean?

.....

(1)

(iv) The student heated a tube containing hydrated copper sulfate.

Name the solid substance produced.

.....

(1)

(Total 8 marks)

Q6. Stage smoke is used for special effects at pop concerts.



By Sam Cockman [CC BY 2.0], via Flickr

Ammonium chloride can be used to make stage smoke.

Ammonium chloride is a white solid.

When heated, ammonium chloride produces white smoke which can be blown onto the stage.

The equation shows what happens when ammonium chloride is heated and cooled.

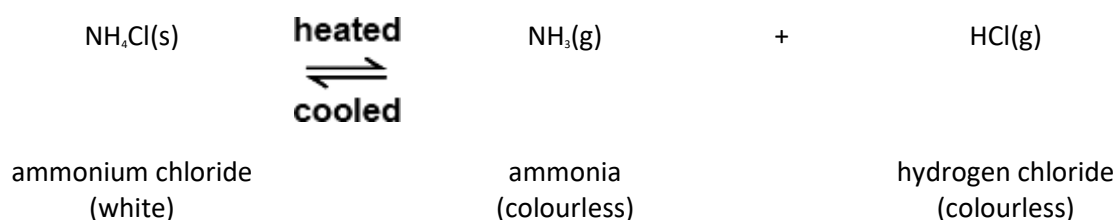

(a) The sentences explain how the smoke is made.

Draw a ring around the correct answer in each box to complete each sentence.

Use the information and the equation to help you.

When heated, ammonium chloride makes two colourless

solids.
liquids.
gases.

These are blown into the air where they cool and make a

colourless	solid.
black	liquid.

white	gas.
-------	------

which is

ammonia. ammonium chloride. hydrogen chloride.

(4)

(b) Complete the sentence.

The symbol \rightleftharpoons means that the reaction is

(1)

(Total 5 marks)

Q7. The flow diagram shows how ammonia is made.

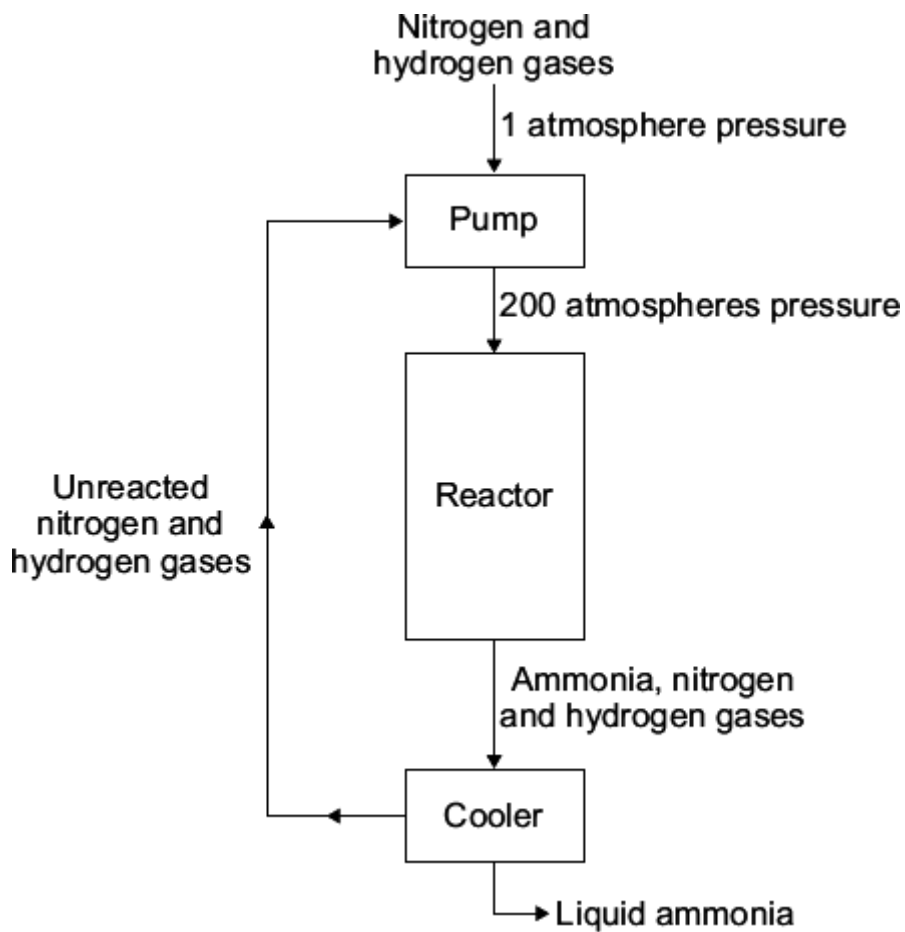

(a) What effect, if any, does the **pump** have on the pressure of the nitrogen and hydrogen?

Draw a ring around the correct answer to complete the sentence.

The pump

decreases
has no effect on
increases

 the pressure.

(1)

(b) The word equation for making ammonia is:



In the **reactor** only a small amount of the nitrogen and hydrogen is changed into ammonia.

Tick (✓) the reason why.

Reason why	Tick (✓)
Ammonia is formed from two elements.	
Nitrogen and hydrogen are gases.	
The reaction is reversible.	

(1)

(c) In the **cooler** the mixture of gases is cooled.

Draw a ring around the correct answer to complete the sentence.

The cooler turns the ammonia into

- a liquid.
- a solid.
- an element.

(1)

(d) What happens to the unreacted nitrogen and hydrogen from the **reactor**?

.....

.....

(1)
(Total 4 marks)

Q8. The diagram shows how anhydrous copper sulfate can be used to test for water.

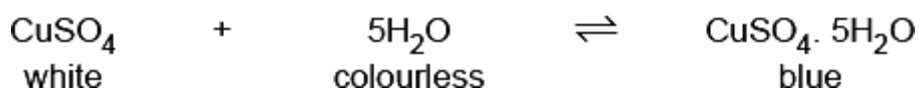
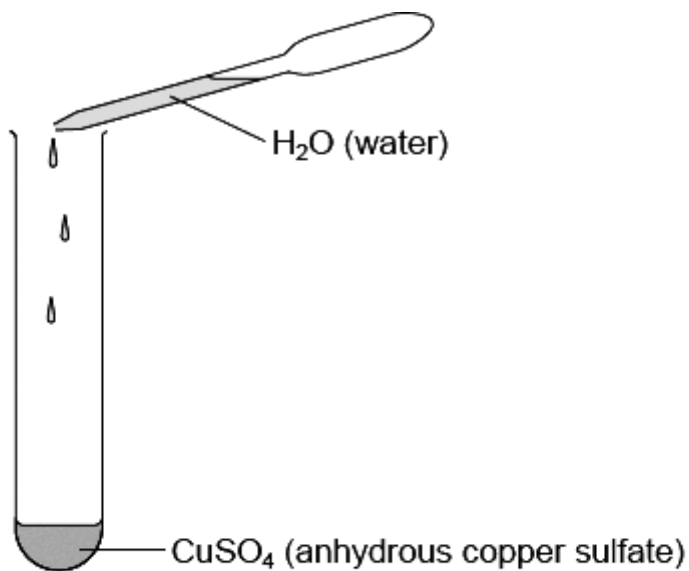

(a) What colour change will you see when water is added to the CuSO_4 ?

Colour changes from to

(1)

(b) Draw a ring around the meaning of the symbol \rightleftharpoons

endothermic

exothermic

reversible

(1)

(Total 2 marks)

Q9. A student heated some hydrated copper sulfate crystals.
The equation for this reaction is shown below.

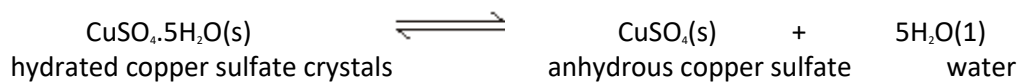

The diagram shows the apparatus used.

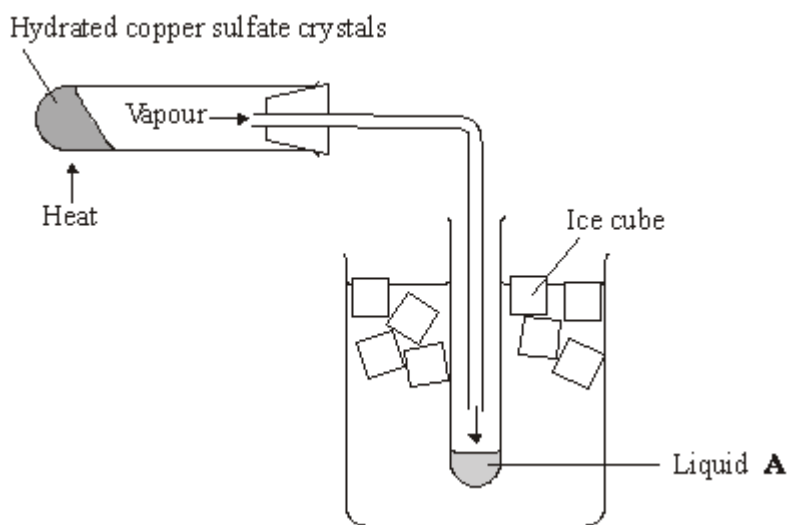

(a) Name liquid **A**

(1)

(b) What helped the vapour to condense into liquid **A**?

.....
.....

(1)

(c) Put a tick (✓) next to the correct meaning of the symbol \rightleftharpoons

Meaning	(✓)
equal amounts of reactants and products	
exothermic reaction	
reversible reaction	

(1)

- (d) The student weighed the copper sulfate before and after it was heated.
The experiment was repeated and the two sets of results are shown in the table.

Mass of copper sulfate before heating in grams	Mass of copper sulfate after heating in grams	Mass lost in grams
2.50	1.65	0.85
2.50	1.61	0.89

- (i) Draw a ring around the **average** mass lost for these two sets of results.

0.85 g 0.87 g 0.89 g

(1)

- (ii) The student used the same mass of copper sulfate each time but the mass lost was different.

Put a tick (✓) next to the **two** reasons which could explain why the mass lost is different.

Reason	(✓)
The student used different test tubes for the two experiments.	
The student made errors in weighing during the experiments.	
The student used more ice in one of the experiments.	
The student did not heat the copper sulfate for long enough in one of the experiments.	

(2)

(e) Anhydrous copper sulfate is used to test for water.

Use words from the box to complete the sentence.

blue	green	red	white
------	-------	-----	-------

Water changes the colour of anhydrous copper sulfate from

to

(2)

(Total 8 marks)

Q10. The Haber process is named after the German chemist, Fritz Haber. The diagram shows the main stages in the Haber process.

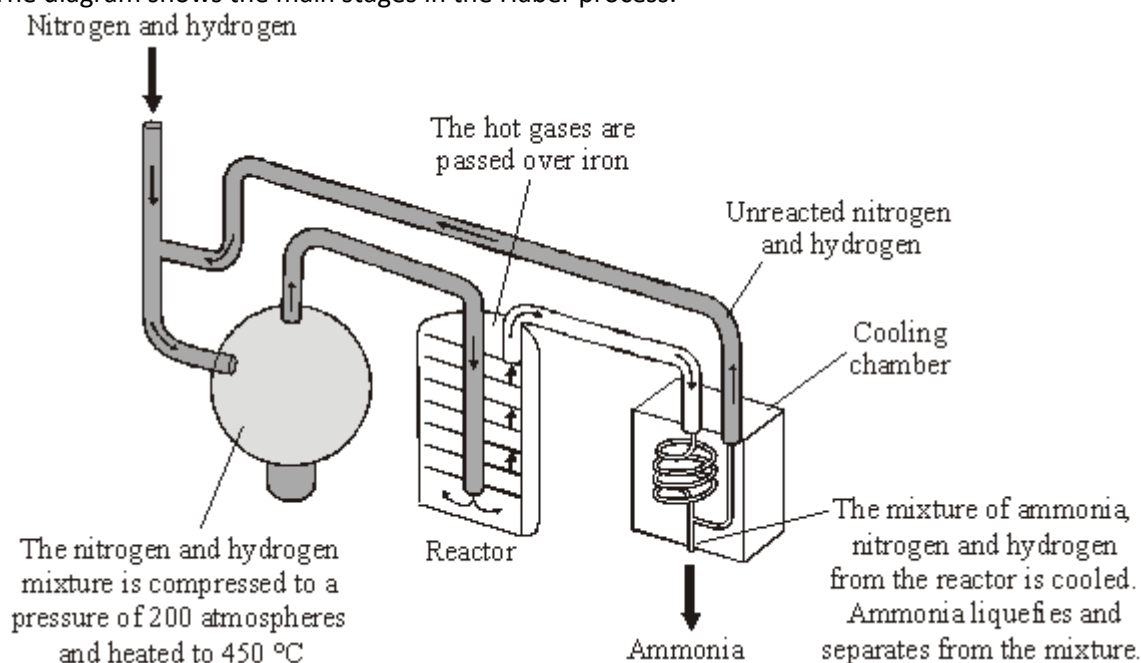

Reproduced with the permission of Nelson Thornes Ltd from PATRICK FULLICK et al, ISBN 0-7487-9644-4. First published in 2006

(a) Use the diagram to help you to answer these questions.

(i) Complete the word equation for the reaction that takes place in the reactor.



(1)

(ii) What does the symbol \rightleftharpoons mean?

.....

(1)

(iii) What is the purpose of the iron in the reactor?

.....

(1)

(iv) Ammonia is separated from unreacted nitrogen and hydrogen.

Draw a ring around the physical property that allows this separation to take place.

boiling point density melting point

(1)

(v) What is done with the unreacted nitrogen and hydrogen?

.....

(1)

(b) Some of the products that can be made from ammonia are:

- fertilisers
- dyes
- explosives
- medicines
- plastics

(i) The Haber process was invented a few years before the start of the First World War. It is thought that the First World War would have finished earlier if the Germans had **not** invented the Haber process.

Suggest why.

.....

.....

(1)

(ii) The Haber process has helped to increase food production.

Explain why.

.....

.....

(1)

(c) Factories that make ammonia are very large and operate night and day.

(i) Ammonia factories are often near towns.

Suggest why.

.....

(1)

- (ii) Suggest and explain **one** reason why local people might not want an ammonia factory near their town.

.....

.....

.....

.....

(2)

(Total 10 marks)