

1 Compound **G** was extracted from the leaves of a plant. A sample of **G** was analysed by a research chemist. A summary of the chemist's results is shown in the table.

type of analysis	evidence
infrared spectroscopy	absorptions at 1080, 1720 and a very broad absorption at $2900\text{ cm}^{-1}$
percentage composition by mass	C, 26.7%; H, 2.22%; O, 71.1%
volumetric analysis	0.00105 mol of <b>G</b> has a mass of 0.0945 g

Use this information to suggest a possible structure for compound **G**.



*In your answer, you should make clear how your explanation is linked to the evidence.*

.....

.....

.....

.....

.....

.....

.....

.....

.....

.....

.....

.....

.....

.....

.....

.....

.....

.....

.....

.....

.....

.....

.....

.....  
.....  
.....  
.....  
.....  
.....  
.....  
.....  
.....  
.....  
.....  
.....  
.....  
.....

..... [8]  
**[Total: 8]**

2 Mass spectrometry is used in analysis.

(a) Compound **O** contains carbon, hydrogen and oxygen.

The mass spectrum of compound **O** is shown below.

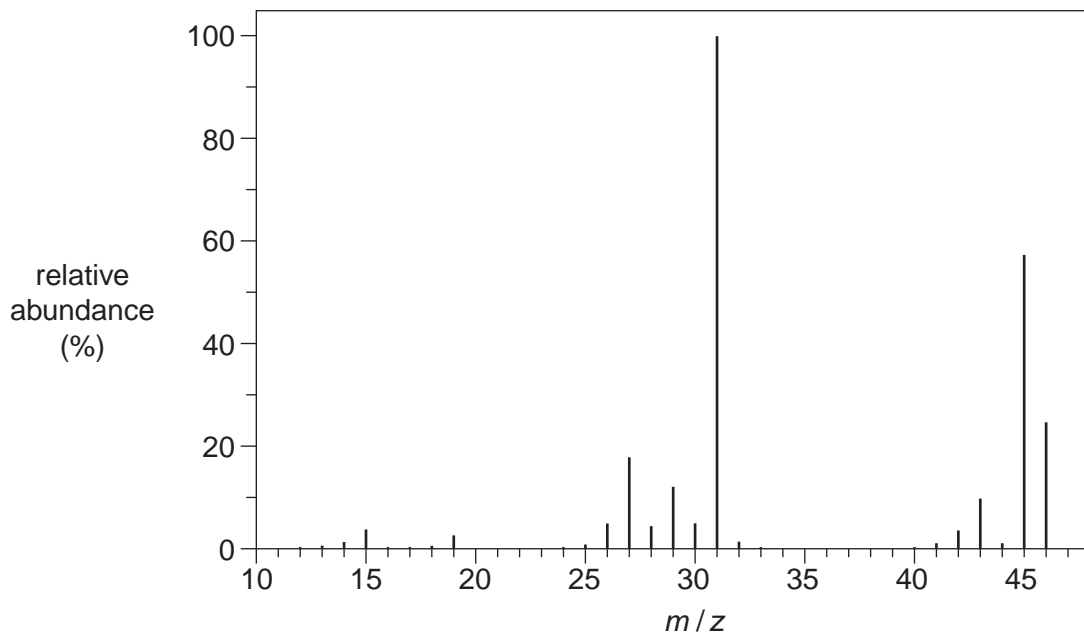

(i) Identify the  $m/z$  value that corresponds to the molecular ion.

..... [1]

(ii) Write the formula of the ion that gives rise to the peak at  $m/z = 31$ .

..... [1]

(iii) Suggest the molecular formula for **O**.

..... [1]

metal the sample contains.

The mass spectrum of the sample shows  $m/z$  peaks as shown in the table.

$m/z$ value	percentage abundance (%)
63	72.2
65	27.8

Positive ions,  $X^+$ , of the metal were responsible for the two  $m/z$  peaks.

Identify the metal **X** by calculating its relative atomic mass to **one decimal place**.

relative atomic mass of **X** = .....

metal **X** = ..... [3]

[Total: 6]

3 Mass spectrometry and infrared spectroscopy are used in analysis.

(a) The mass spectrum of compound **Z** is shown below.

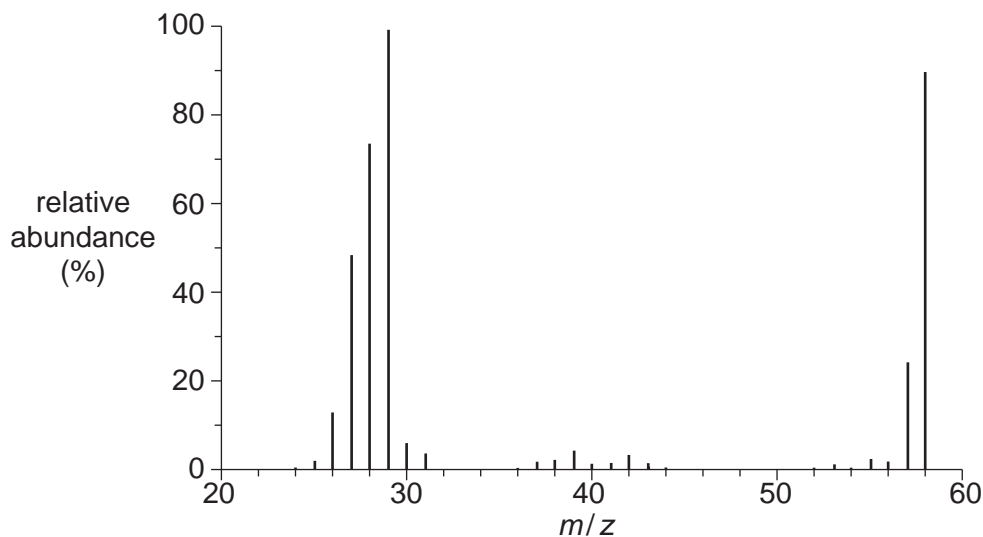

Compound **Z** has the molecular formula  $C_3H_6O_x$ .

(i) Using the mass spectrum, deduce the value of  $x$  in  $C_3H_6O_x$ .

Explain your answer.

.....  
.....  
.....  
..... [2]

(ii) Suggest a possible structure for **Z**.

[1]

(iii) Suggest the formula of an ion that gives rise to the peak at  $m/z = 29$  in this spectrum.

..... [1]

(b) A space probe has detected the presence of the element iron on the surface of the planet Mars.

Outline how a mass spectrum would show the presence of iron.

.....  
..... [1]

(c) The space probe also detected different isotopes of sulfur on Mars.

(i) Outline how the mass spectrum would show how many different isotopes of sulfur were present on Mars.

.....  
.....  
..... [1]

(ii) The relative atomic mass of the sulfur found by the space probe was different from the relative atomic mass of sulfur on Earth.

Suggest why.

.....  
.....  
..... [1]

(d) An environmental chemist used infrared spectroscopy to monitor air pollution outside a petrol station. The infrared spectrum below was obtained from one of these pollutants.

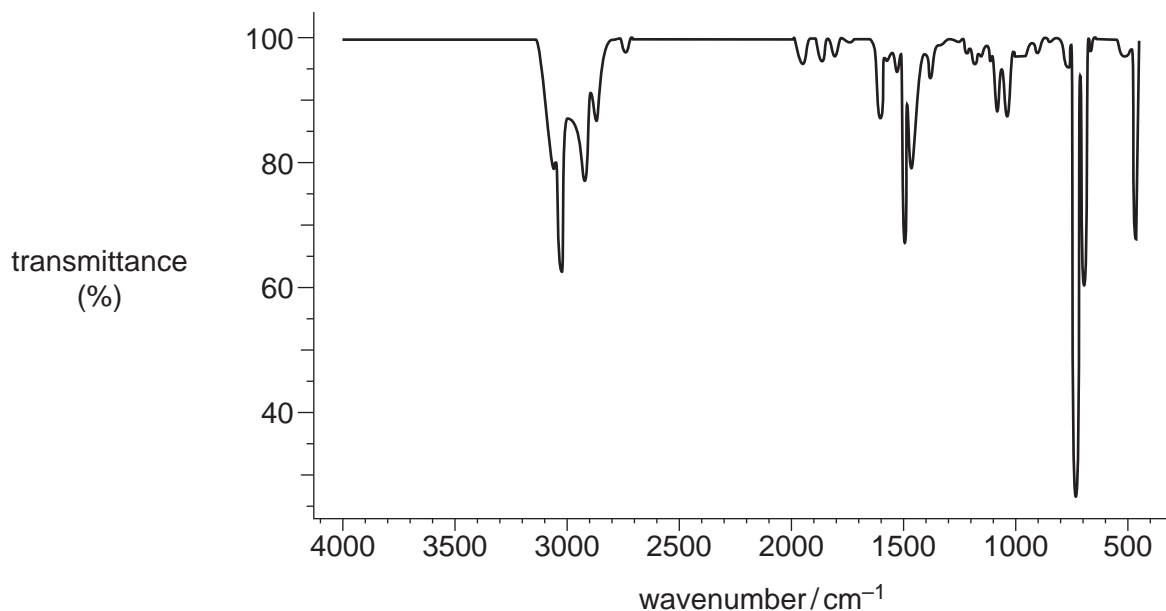

What evidence is there in the spectrum that the pollutant may be a hydrocarbon rather than an alcohol or a carbonyl compound?

.....  
.....  
..... [1]

(e) The infrared spectrum of a drug is shown below.

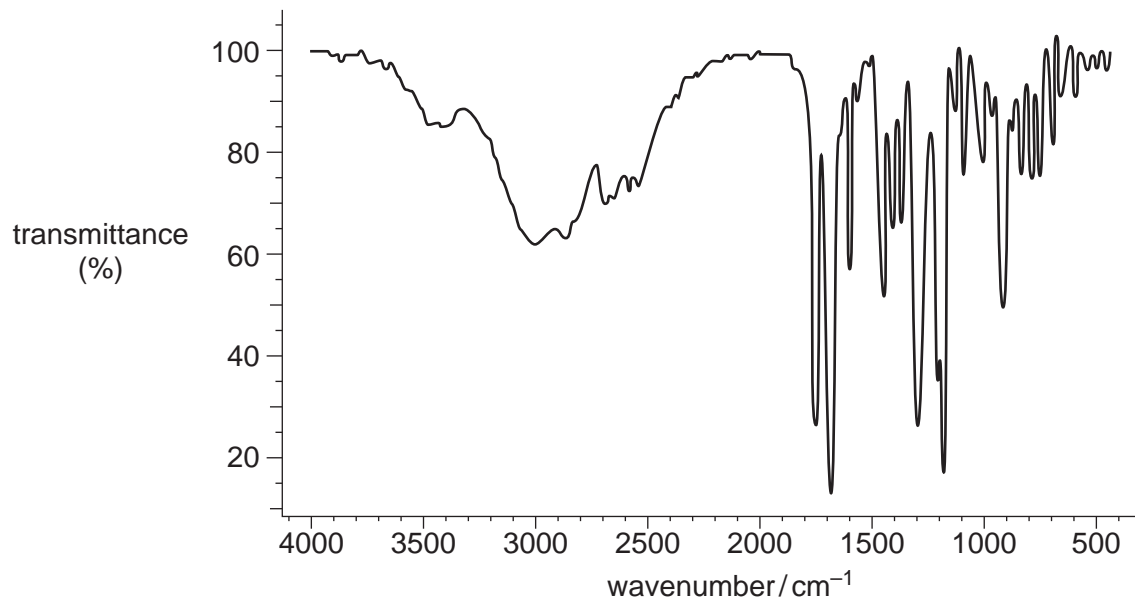

Suggest, with reasons, possible functional group(s) present in the drug.

.....

.....

.....

.....

..... [2]

[Total: 10]

4 This question is about the compounds shown below.

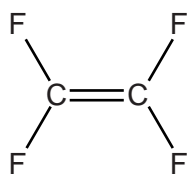

**B**

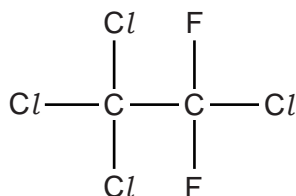

**C**

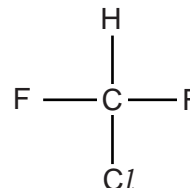

**D**

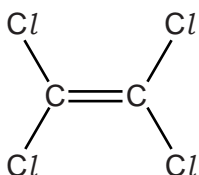

**E**

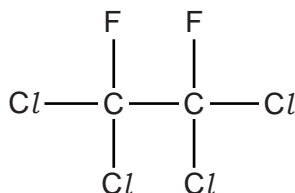

**F**

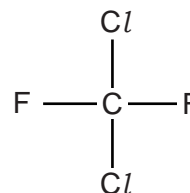

**G**

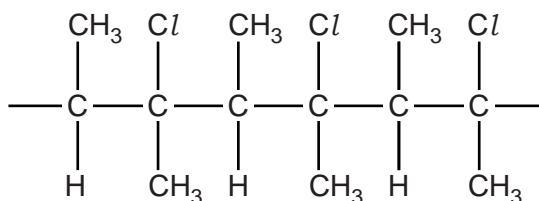

**H**

(a) Which compound, **B** to **H**, could be used to make the polymer PTFE?

..... [1]

(b) Polymer **H** can be disposed of by combustion. One environmental problem is the production of toxic gases, such as CO.

(i) Draw the structure of the monomer needed to produce polymer **H**.

[1]

(ii) Give the formula of an acidic toxic gas that could form during combustion of polymer **H**.

..... [1]



(c) Compound **G** was once used as a propellant in aerosols. Compound **G** has been linked with depletion of the ozone layer in the stratosphere.

(i) State **two** properties that made compound **G** suitable for use as an aerosol.

- 1 .....
- 2 .....

[1]

(ii) Explain the following statements, using equations where appropriate.

- Life on Earth benefits from the presence of an ozone layer.
- The concentration of ozone is maintained in the ozone layer.
- Compound **G** produces radicals which catalyse the breakdown of ozone.

.....  
.....  
.....  
.....  
.....  
.....  
.....  
.....  
.....  
.....  
.....  
.....  
.....  
.....  
.....  
.....  
.....  
.....  
.....  
.....

[5]

(iii) Alternative ‘ozone-friendly’ compounds are now used as propellants instead of compound **G**.

Which compound, **B** to **H**, might be suitable as an ‘ozone-friendly’ propellant?

.....

[1]

(d) Compounds **C** and **F** can be analysed to obtain infrared and mass spectra.

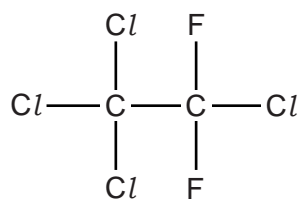

**C**

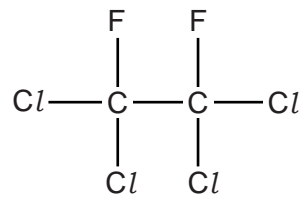

**F**

(i) What happens to molecules when infrared radiation is absorbed?

..... [1]

(ii) Suggest the molecular formulae of **two** ions responsible for peaks in the mass spectrum of **C** that are **not** in the mass spectrum of **F**.

.....

..... [2]

[Total: 13]

5 A branched-chain alcohol **J** is a liquid and has the molecular formula  $C_5H_{12}O$ .

(a) A student does an experiment to measure the enthalpy change of combustion,  $\Delta H_c$ , of alcohol **J**.

(i) The student burns alcohol **J** using the apparatus below.

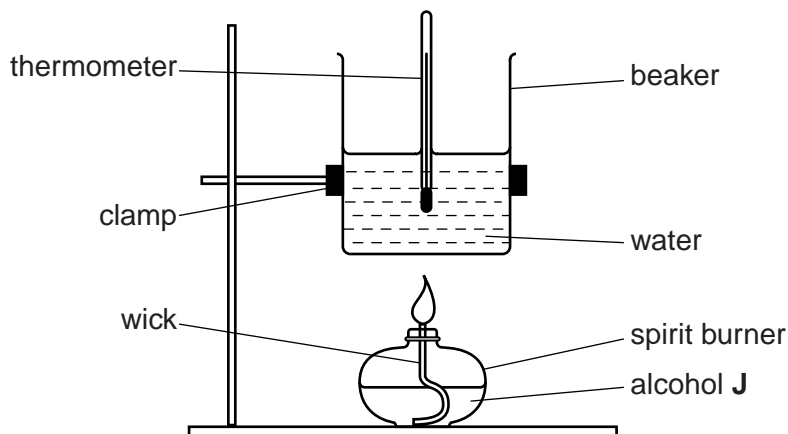

The student found that combustion of 1.54 g of alcohol **J** changes the temperature of 180 g of water from 22.8 °C to 75.3 °C.

The specific heat capacity of water is  $4.18 \text{ J g}^{-1} \text{ K}^{-1}$ .

- Calculate the amount, in mol, of alcohol **J** that burns.
- Calculate the enthalpy change of combustion,  $\Delta H_c$ , of alcohol **J**, in  $\text{kJ mol}^{-1}$ .

Give your final answer to **three** significant figures.

$\Delta H_c = \dots\dots\dots \text{kJ mol}^{-1}$  [4]

- (ii) The calculated value of  $\Delta H_c$  from this experiment is different from the value obtained from data books.

Apart from heat loss, suggest **two** reasons for the difference.

Assume that the calculation has been carried out correctly.

.....  
.....  
.....  
..... [2]

- (b) The enthalpy change of combustion for alcohol **J** can also be determined indirectly from standard enthalpy changes of formation.

- (i) Write an equation, including state symbols, for the chemical change that represents the standard enthalpy change of formation of the liquid alcohol **J**,  $C_5H_{12}O$ .

..... [1]

- (ii) The equation for the complete combustion of alcohol **J** is shown below.

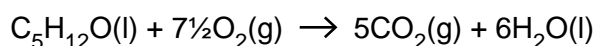

Enthalpy changes of formation,  $\Delta H_f$ , are shown in the table.

Substance	$C_5H_{12}O(l)$	$CO_2(g)$	$H_2O(l)$
$\Delta H_f / kJ mol^{-1}$	-366	-394	-286

Calculate the enthalpy change of combustion,  $\Delta H_c$ , of alcohol **J** from the information given above.

$$\Delta H_c = \dots\dots\dots kJ mol^{-1} \quad [3]$$



**(d)** The alcohol **J** is soluble in water.

Explain why alcohol **J** is soluble in water.

Use a labelled diagram to support your answer.

Include relevant dipoles and lone pairs.

.....

.....

..... [1]

**[Total: 17]**

6 A student carries out an investigation on some halogenoalkanes.

(a) She decided to hydrolyse 1-bromopentane and 1-chloropentane using aqueous sodium hydroxide.

State and explain the difference in the rates of hydrolysis of 1-bromopentane and 1-chloropentane.

.....  
.....  
.....  
..... [2]

(b) A student wants to determine the structure of an unknown iodoalkane **B**.

She knows that the molecular formula of **B** is  $C_4H_9I$ .

The student heats **B** with aqueous sodium hydroxide. A reaction mixture forms containing the organic compound **C** and  $I^-(aq)$ .

(i) Draw all of the possible structural isomers for **B**.

[4]

(ii) What is the molecular formula for compound **C**?

..... [1]

(iii) The student purifies compound **C** and splits it into two portions.

- She heats one portion of **C** with concentrated sulfuric acid. The product of this reaction is methylpropene.
- To the other portion of **C**, she adds acidified potassium dichromate(VI) and heats the mixture under reflux. The product of this reaction is compound **D**.
- The infrared spectrum for compound **D** is shown at the top of page 19.

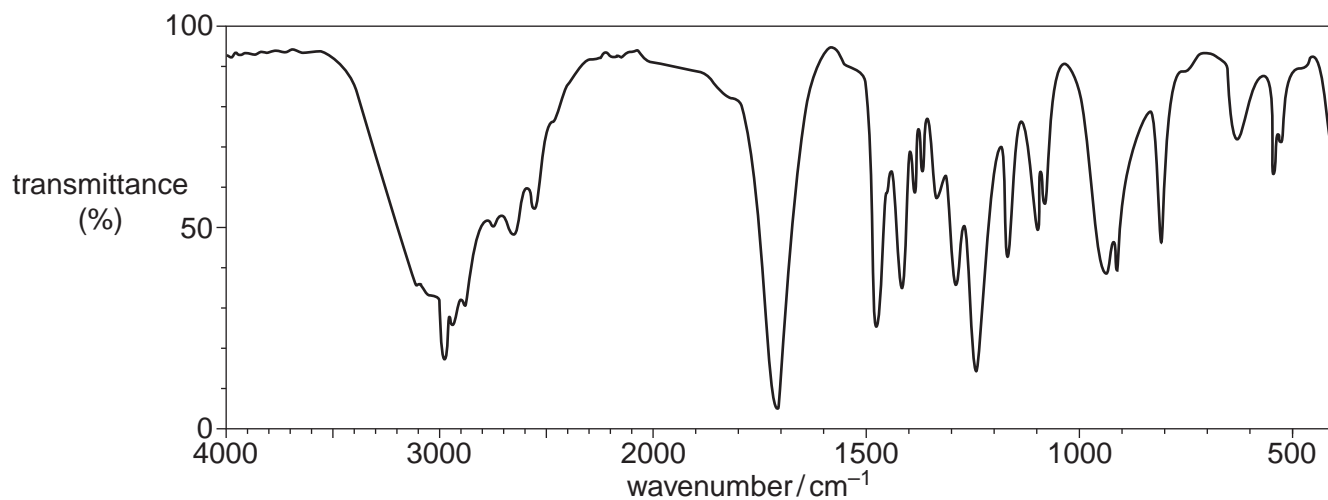

Use this evidence to suggest structures for **B**, **C** and **D**.



*In your answer you should make clear how your explanations are linked to the evidence.*

.....

.....

.....

.....

.....

.....

.....

.....

.....

.....

.....

.....

.....

.....

.....

.....

.....

.....

.....

.....

.....

.....

.....



.....

.....

.....

.....

.....

.....

.....

.....

.....

.....

.....

.....

.....

.....

.....

.....

.....

**[6]**

**[Total: 13]**