

Version 1.0



**General Certificate of Education (A-level)
June 2013**

Chemistry

CHEM4

(Specification 2420)

**Unit 4: Kinetics, Equilibria and Organic
Chemistry**

Final

Mark Scheme

Mark schemes are prepared by the Principal Examiner and considered, together with the relevant questions, by a panel of subject teachers. This mark scheme includes any amendments made at the standardisation events which all examiners participate in and is the scheme which was used by them in this examination. The standardisation process ensures that the mark scheme covers the candidates' responses to questions and that every examiner understands and applies it in the same correct way. As preparation for standardisation each examiner analyses a number of candidates' scripts: alternative answers not already covered by the mark scheme are discussed and legislated for. If, after the standardisation process, examiners encounter unusual answers which have not been raised they are required to refer these to the Principal Examiner.

It must be stressed that a mark scheme is a working document, in many cases further developed and expanded on the basis of candidates' reactions to a particular paper. Assumptions about future mark schemes on the basis of one year's document should be avoided; whilst the guiding principles of assessment remain constant, details will change, depending on the content of a particular examination paper.

Further copies of this Mark Scheme are available from: aqa.org.uk

Copyright © 2013 AQA and its licensors. All rights reserved.

Copyright

AQA retains the copyright on all its publications. However, registered centres for AQA are permitted to copy material from this booklet for their own internal use, with the following important exception: AQA cannot give permission to centres to photocopy any material that is acknowledged to a third party even for internal use within the centre.

Set and published by the Assessment and Qualifications Alliance.

Mark Scheme – General Certificate of Education (A-level) Chemistry – Unit 4: Kinetics, Equilibria and Organic Chemistry – June 2013

Question	Marking Guidance	Mark	Comments
1(a)(i)	2 or two or second or $[E]^2$	1	
1(a)(ii)	1 or one or first or $[F]^1$ or $[F]$	1	
1(b)(i)	$k = \frac{8.6 \times 10^{-4}}{(3.8 \times 10^{-2})^2 \times (2.6 \times 10^{-2})}$	1	mark is for insertion of numbers into a correctly rearranged rate equ , $k =$ etc. AE (-1) for copying numbers wrongly or swapping two numbers.
	= 22.9 (Allow 22.9 – 24 after correct rounding)	1	
	<u>$\text{mol}^{-2} \text{dm}^6 \text{s}^{-1}$</u>	1	Any order.
1(b)(ii)	$6.8(2) \times 10^{-3} \quad (\text{mol dm}^{-3} \text{s}^{-1})$ OR if their k is wrong, award the mark consequentially a quick check can be achieved by using <u>their answer</u> = 2.9768×10^{-4} Allow $2.9 - 3.1 \times 10^{-4}$ for the mark their k	1	Allow 6.8×10^{-3} to 6.9×10^{-3} Ignore units.

Question	Marking Guidance		Mark	Comments
2(a)	Cl ₂	0.4	1	
	NOCl	1.7	1	
2(b)(i)	$K_c = \frac{[\text{NO}]^2[\text{Cl}_2]}{[\text{NOCl}]^2}$		1	Penalise expression containing V Allow () here, but must have all brackets. If K_c expression wrong, max 2 in (b)(ii) for M1 for correct rearrangement of their K_c and M4 for multiplying by 15
2(b)(ii)	M1	$[\text{Cl}_2] = K_c \times \frac{[\text{NOCl}]^2}{[\text{NO}]^2}$	1	Mark is for rearrangement of correct K_c expression. If K_c rearrangement wrong, can only score max 2 for: M3 and M4
	M2	$[\text{Cl}_2] = \frac{(7.4 \times 10^{-3}) \times (1.90/15)^2}{(0.86/15)^2} (= \frac{(7.4 \times 10^{-3}) \times (0.127)^2}{(0.0573)^2})$	1	Rounding 1.90/15 wrongly to 0.126 is AE
	M3	[Cl ₂] = 0.0361 to 0.0365 (min 2 sfs)	1	Mark for correct calculation of [Cl ₂]
	M4	mol Cl ₂ = 0.54 to 0.55	1	Correct answer scores 4 ignore working Mark is for <u>answer</u> of (M3 × 15)

2(b)(iii)	$(\sqrt{7.4 \times 10^{-3}} =) \quad 0.086$ Allow 0.085 to 0.086)	1	Mark for answer OR conseq on their Cl ₂ $K_c = \sqrt{\frac{M4}{15}} \times \frac{0.86}{1.90} = \sqrt{M4} \times 0.117$ Or $\sqrt{M3} \times 0.453$
	<u>mol^{1/2} dm^{-3/2}</u> OR <u>mol^{0.5} dm^{-1.5}</u>	1	NOT $\sqrt{\text{mol dm}^{-3}}$ nor $(\text{mol dm}^{-3})^{1/2}$

Question	Marking Guidance		Mark	Comments
3(a)	Proton donor or H ⁺ donor		1	
3(b)(i)	$K_a = \frac{[\text{CH}_3\text{COO}^-][\text{H}^+]}{[\text{CH}_3\text{COOH}]}$ or $\frac{[\text{CH}_3\text{COO}^-][\text{H}_3\text{O}^+]}{[\text{CH}_3\text{COOH}]}$		1	If K_a wrong, can only score M1 below. Must be ethanoic acid not HA Must have square brackets (penalise here only) but mark on in (b)(ii).
3(b)(ii)	M1	$[\text{H}^+] = 10^{-2.69}$ OR 2.042×10^{-3} (mol dm ⁻³)	1	
	M2	$[\text{CH}_3\text{COOH}] = \frac{[\text{H}^+]^2}{K_a}$	1	Ignore () Mark for correctly rearranged expression incl $[\text{H}^+]^2$
	M3	$= \frac{(2.042 \times 10^{-3})^2}{1.75 \times 10^{-5}}$	1	If M2 wrong no further marks.
	M4	$= 0.238$ (mol dm ⁻³) Allow 0.229 – 0.24	1	
3(c)(i)	$\text{ClCH}_2\text{COOH} \rightleftharpoons \text{ClCH}_2\text{COO}^- + \text{H}^+$ OR $\text{ClCH}_2\text{COOH} + \text{H}_2\text{O} \rightleftharpoons \text{ClCH}_2\text{COO}^- + \text{H}_3\text{O}^+$		1	Allow → Allow ClCH ₂ CO ₂ H and ClCH ₂ CO ₂ ⁻
3(c)(ii)	M1	Cl is (more electronegative so) withdraws electrons OR negative inductive effect of Cl	1	Ignore electronegativity. Ignore chloroethanoic acid has a lower K_a value. Allow Cl reduces +ve inductive effect of methyl group.
	M2	Weakens O—H bond OR O—H bond is more polar OR reduces negative charge on COO ⁻ OR stabilizes COO ⁻ (more)	1	M1 & M2 are independent marks. Ignore H ⁺ lost more easily.

Mark Scheme – General Certificate of Education (A-level) Chemistry – Unit 4: Kinetics, Equilibria and Organic Chemistry – June 2013

3(d)(i)	A		1	
3(d)(ii)	C		1	
3(d)(iii)	D		1	
3(e)	M1	Mol NaOH = mol OH ⁻ = $(19.6 \times 10^{-3}) \times 0.720 = 1.41(1) \times 10^{-2}$	1	Mark for answer.
	M2	Mol H ₂ SO ₄ = $(26.4 \times 10^{-3}) \times 0.550 = 1.45(2) \times 10^{-2}$	1	Mark for answer.
	M3	Mol H ⁺ added = 2 × $(1.452 \times 10^{-2}) = 2.90(4) \times 10^{-2}$ OR XS mol H ₂ SO ₄ = $7.46(4) \times 10^{-3}$	1	If factor × 2 missed completely (pH = 2.05) or used wrongly later, can score max 4 for M1, M2, M5 & M6
	M4	XS mol H ⁺ = 0.0149(3)	1	
	M5	For dividing by volume [H ⁺] = $0.0149(3) \times (1000 / 46.0) = 0.324 - 0.325 \text{ mol dm}^{-3}$	1	If no use or wrong use of volume lose M5 and M6 ie can score 4 for pH = 1.83 (no use of vol) Treat missing 1000 as AE (-1) & score 5 for pH = 3.49
	M6	pH = 0.49	1	2dp (penalise more or less).

Question	Marking Guidance	Mark	Comments
4(a)	$\left[\begin{array}{c} \text{H}_3\text{C}-\text{C}-\text{O}-\text{CH}_3 \\ \\ \text{O} \end{array} \right]^+\bullet$ <p>OR $\left[\text{C}_3\text{H}_6\text{O}_2 \right]^+\bullet$</p>	1	NOT penalise missing brackets. If wrong ester, no further mark.
	$\rightarrow \begin{array}{c} \text{H}_3\text{C}-\text{C}^+ \\ \\ \text{O} \end{array} + \begin{array}{c} \text{H} \\ \\ \bullet\text{O}-\text{C}-\text{H} \\ \\ \text{H} \end{array}$ <p>(1)</p> <p>Radical dot must be on O Ignore lone pair(s) on O in addition to single electron</p>	1	Allow radical with brackets as $\left[\begin{array}{c} \text{H} \\ \\ \text{O}-\text{C}-\text{H} \\ \\ \text{H} \end{array} \right]^\bullet$ Ignore errors in acylium ion.

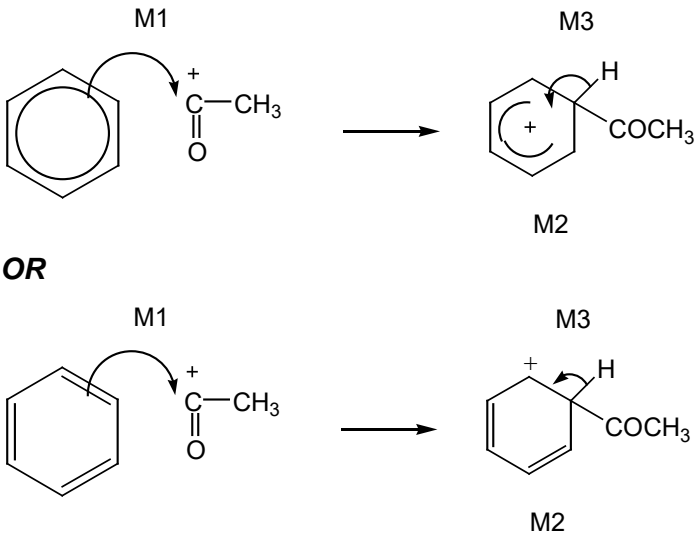
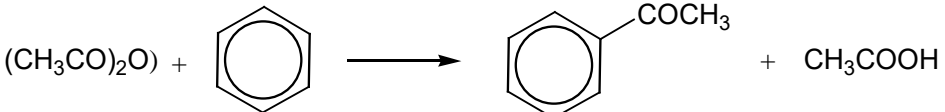
4(b)(i)	AlCl ₃ or FeCl ₃	1	If wrong no further marks.
	$\text{CH}_3\text{COCl} + \text{AlCl}_3 \longrightarrow \text{CH}_3\text{CO}^+ + \text{AlCl}_4^-$	1	Correct equation scores 2 - contrast with 4(b)(iii) Allow + on C or O in equation.
4(b)(ii)	<p>Electrophilic substitution</p>  <p>OR</p>	1	<p>Ignore Friedel crafts.</p> <ul style="list-style-type: none"> + must be on C of RCO here M1 arrow from within hexagon to C or to + on C Gap in horseshoe must approximately be centred around C1 and not extend towards C1 beyond C2 and C6 + not too close to C1 M3 arrow into hexagon unless Kekule allow M3 arrow independent of M2 structure, i.e. + on H in intermediate loses M2 not M3 ignore base removing H for M3
4(b)(iii)	$(\text{CH}_3\text{CO})_2\text{O} + \text{C}_6\text{H}_6 \rightarrow \text{C}_6\text{H}_5\text{COCH}_3 + \text{CH}_3\text{COOH}$ <p>OR</p> 	1	<p>Correct equation scores 1 – contrast with 4(b)(i)</p> <p>Not allow molecular formula for ethanoic anhydride or ethanoic acid.</p>

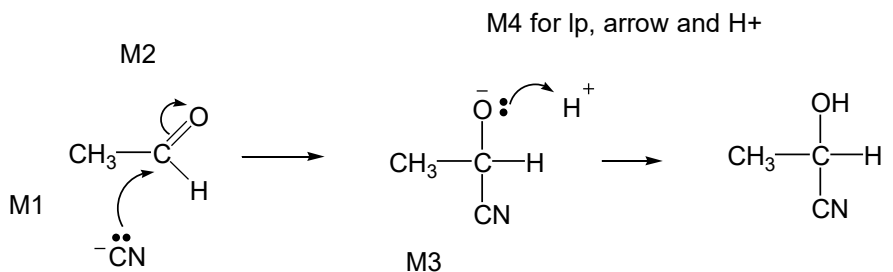
Question	Marking Guidance	Mark	Comments
5(a)(i)	<u>2-hydroxypropanoic acid</u> OR <u>2-hydroxypropan(-1-)oic acid</u>	1	Do not penalise different or missing punctuation or extra spaces. Spelling must be exact and order of letters and numbers as here. Can ignore -1- before –oic, but penalise any other numbers here.
5(a)(ii)	$C_{12}H_{22}O_{11} + H_2O \rightarrow 4CH_3CH(OH)COOH$ OR $C_{12}H_{22}O_{11} + H_2O \rightarrow 2CH_3CH(OH)COOH + C_6H_{12}O_6$	1	Allow $4C_3H_6O_3$ Allow $2C_3H_6O_3$
5(b)(i)	<u>Nucleophilic addition</u> 	1 4	<ul style="list-style-type: none"> • M1 lp <u>and minus</u> must be on C • M1 and M4 include lone pair and curly arrow. • M2 not allowed independent of M1, but allow following some attempt at attack on carbonyl C • allow M1 for correct attack on C+ • + rather than $\delta+$ on C=O loses M2 • M3 is for correct structure including minus sign but lone pair is part of M4 • Allow arrow in M4 to H of H-CN with arrow forming cyanide ion.
5(b)(ii)	<u>Equal</u> mixture of enantiomers / (optical) isomers	1	
5(b)(iii)	(Plane) polarized light	1	If missing no further mark.
	(Polarised light) <u>rotated</u> by single enantiomer but unaffected by racemate	1	Both needed; not allow bend, twist etc.

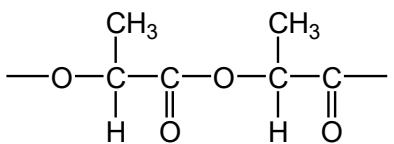
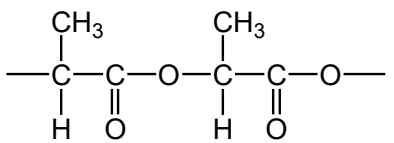
5(c)(i)	$\text{CH}_3\text{CH}(\text{OH})\text{COOH} + \text{NaOH} \rightarrow \text{CH}_3\text{CH}(\text{OH})\text{COONa} + \text{H}_2\text{O}$ OR $\text{CH}_3\text{CH}(\text{OH})\text{COOH} + \text{OH}^- \rightarrow \text{CH}_3\text{CH}(\text{OH})\text{COO}^- + \text{H}_2\text{O}$		1	Not ambiguous mol formulae for product - must show COONa or CO ₂ Na or COO ⁻ or CO ₂ ⁻
5(c)(ii)	[H ⁺] = K _a OR pH = pK _a		1	
	pH = 3.86		1	Allow more than 2 decimal places but not fewer.
5(c)(iii)	M1	buffer	1	Ignore acidic but penalise alkaline or basic.
	Any two out of the three marks M2 , M3 & M4			
	M2	Large lactate concentration in buffer OR sodium lactate completely ionised	Max 2	Ignore reaction of H ⁺ with OH ⁻ Ignore reference to equilibrium unless it is shown.
	M3	added acid reacts with/is removed by lactate ion or A ⁻ or sodium lactate or salt OR equation $\text{H}^+ + \text{A}^- \rightarrow \text{HA}$		
M4	ratio [HA]/[A ⁻] stays almost constant	Ignore H ⁺ or pH remains constant.		
5(d)(i)	 OR 		No marks if ester link missing Correct ester link allow —COO—	NB Correct answer scores 2
			All rest correct with trailing bonds	1 1 Ignore <i>n</i> here (compare with 5(d)(iv)). Ignore brackets. If OH or COOH on either or both ends, lose one, ie dimer scores 1 If more than two repeating units, lose 1
5(d)(ii)	(Poly)ester ie allow ester		1	Not terylene. Ignore spaces and brackets in answer.

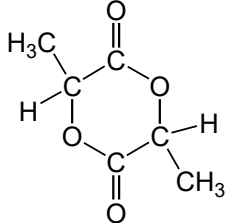
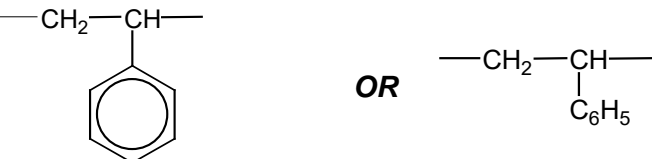
5(d)(iii)		1	Allow any <u>cyclic C₆H₈O₄</u>
5(d)(iv)		1	Penalise <i>n</i> here (compare with 5(d)(i)) Ignore brackets. Not allow Ph for phenyl.
5(d)(v)	In landfill, no air or UV, to assist decay OR not enough water or moisture (to hydrolyse polyester)	1	Allow landfill has/contains: no or few bacteria / micro-organisms / enzymes compared with compost heap OR less oxygen OR <u>lower</u> temperature.

Question	Marking Guidance	Mark	Comments
6(a)	$\begin{array}{c} \text{H} \\ \\ \text{H}_3\text{C}-\text{C}-\text{COO}^- \\ \\ + \text{NH}_3 \end{array}$	1	Allow $-\text{NH}_3^+$ and $^+\text{NH}_3-$
6(b)	$\begin{array}{c} \text{H} \\ \\ \text{H}_3\text{C}-\text{C}-\text{COOCH}_3 \\ \\ \text{NH}_2 \end{array}$	1	Allow protonated form, i.e. $-\text{NH}_3^+$ or $^+\text{NH}_3-$
6(c)	$\begin{array}{c} \text{COO}^- \\ \\ \text{H}-\text{C}-\text{CH}_2\text{COO}^- \\ \\ \text{NH}_2 \end{array}$	1	Allow $-\text{CO}_2^-$
6(d)	$\begin{array}{c} \text{COOH} \quad \text{COOH} \\ \quad \quad \\ \text{CH}_2 \quad \text{CH}_2 \\ \quad \quad \\ \text{H}_2\text{N}-\text{C}-\text{C}-\text{N}-\text{C}-\text{COOH} \\ \quad \quad \quad \quad \\ \text{H} \quad \quad \text{O} \quad \text{H} \quad \text{H} \end{array}$	1	<p>Allow zwitterion with any COO^-</p> <p>Allow use of “wrong” COOH</p> $\begin{array}{c} \text{COOH} \quad \text{COOH} \\ \quad \quad \\ \text{CH}_2 \quad \text{CH}_2 \\ \quad \quad \\ \text{H}_2\text{N}-\text{C}-\text{CH}_2-\text{C}-\text{N}-\text{C}-\text{COOH} \\ \quad \quad \quad \quad \\ \text{H} \quad \quad \text{O} \quad \text{H} \quad \text{H} \end{array}$

Question	Marking Guidance	Mark	Comments
7(a)(i)	CDCl_3 or CD_2Cl_2 or C_6D_6 or CCl_4	1	Not D_2O Allow CD_3Cl
7(a)(ii)	4 or four	1	
7(a)(iii)	Triplet or 3 or three	1	
7(a)(iv)	<u>1,4-dichloro-2,2-dimethylbutane</u>	1	Do not penalise different or missing punctuation or extra spaces. Spelling must be exact and order of letters and numbers as here.
7(b)(i)	3 or three	1	
7(b)(ii)	190-220 (cm^{-1})	1	Allow a single number within the range. OR a smaller range entirely within this range.
7(b)(iii)	<u>hexane-2,5-dione</u>	1	Do not penalise different or missing punctuation or extra spaces. Spelling must be exact and order of letters and numbers as here. NB so must have middle e

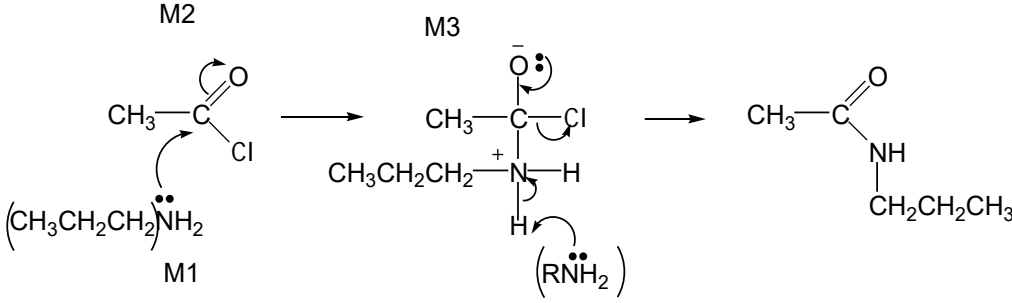
Question	Marking Guidance	Mark	Comments
8(a)	<p>(nucleophilic) addition-elimination</p>  <p>M4 for 3 arrows and lp</p> <p>Allow wrong amine in M1 but penalise in M3</p> <p>Allow C₃H₇ in M3</p> <p>Minus sign on NH₃ loses M1 (but not M4 if NH₃ also shown here)</p>	1	<ul style="list-style-type: none"> • Allow attack by :NH₂CH₂CH₂CH₃ • M2 not allowed independent of M1, but allow M1 for correct attack on C⁺ • + rather than δ⁺ on C=O loses M2 • If Cl lost with C=O breaking, max1 for M1 • M3 for correct structure <u>with charges</u> but lone pair on O is part of M4 • 3 arrows in M4 can be shown in two separate steps. • If M3 drawn twice, mark first answer eg ignore missing + if missed off second structure • Only allow M4 after correct / very close M3 • For M4, ignore RNH₂ removing H⁺ but lose M4 for Cl⁻ removing H⁺ in mechanism, • but ignore HCl shown as a product.
	<u>N-propylethanamide</u> must be this name even if wrong amine used	1	NOT N-propylethanamide

8(b)(i)	$\begin{array}{c} \text{H}_3\text{C}-\text{CH}-\text{CH}_3 \\ \\ \text{NH}_2 \end{array}$	Primary	Not allow ambiguous $\text{C}_3\text{H}_7\text{NH}_2$ BEWARE No mark for the original amine $\text{CH}_3\text{CH}_2\text{CH}_2\text{NH}_2$	1	Label and structure must both be correct for each type to score the mark. Penalize wrong number of carbons but otherwise correct, first time only.
	$\begin{array}{c} \text{H}_3\text{C}-\text{N}-\text{CH}_2\text{CH}_3 \\ \\ \text{H} \end{array}$	secondary	Allow C_2H_5	1	
	$\begin{array}{c} \text{H}_3\text{C}-\text{N}-\text{CH}_3 \\ \\ \text{CH}_3 \end{array}$	tertiary		1	
8(b)(ii)	Absorption at <u>3300-3500</u> (cm^{-1}) in spectrum			1	Allow trough, peak, spike. Ignore absorption at 750 – 1100 for C—C bond in secondary - this is within fingerprint region. Allow any number in this range. If range missing, no further marks. If range linked to tertiary, no further marks.
	N—H (bond) (only) present in secondary amine or not present in tertiary amine OR This peak or N—H absorption (only) present in spectrum of secondary amine or not present in spectrum of tertiary amine			1	

Mark Scheme – General Certificate of Education (A-level) Chemistry – Unit 4: Kinetics, Equilibria and Organic Chemistry – June 2013

8(c)(i)	M1	Route A : stage 1	KCN		1	Apply list principle for extra reagents or catalysts NOT HCN NOT KCN/acid Not KCN/HCN
	M2		Aqueous or ethanolic		1	M2 only scores after correct M1 ignore warm; acid here loses M1 & M2
	M3	Route A Intermediate	CH ₃ CH ₂ CN or propanenitrile Name alone must be exactly correct to gain M1 but mark on if name close correct formula gains M1 (ignore name if close) contradiction of name and formula loses mark		1	If M3 intermediate wrong, max 2 for M1 & M2 ie no mark for stage 2 But if M3 intermediate close, eg “nitrile” or wrong nitrile, can award marks in stage 2 If stage 1 correct and intermediate is missing, can award marks in stage 2 stage 1 wrong & intermediate missing, no marks.
	M4	Route A : stage 2	H ₂ H loses M4 but mark on	LiAlH ₄	1	Apply list principle for extra reagents or catalysts. M5 only scores after correct M4 Not NaBH ₄ not Sn or Fe / HCl Allow (dil) acid after but not with LiAlH ₄ Penalise conc acid.
	M5		Ni or Pt or Pd	ether	1	
	M6	Route B	NH ₃		1	With acid loses M6 & M7 Apply list principle for extra reagents or catalysts.
	M7		Excess NH ₃		1	Ignore conc, ignore high P, ignore solvent.
8(c)(ii)	Route A disadv		Toxic /poisonous KCN or cyanide or CN ⁻ or HCN OR lower <u>yield</u> because 2 steps	Expensive LiAlH ₄ Ignore acidified	1	Allow H ₂ flammable/explosive etc. Not just dangerous. Ignore time reasons.
	Route B disadv		Further reaction/substitution likely		1	Allow impure product.

Question	Marking Guidance		Mark	Comments
9(a)	M1	<u>Lone pair on N labelled b more available / more able to be donated than lone pair on N labelled a</u>	1	Ignore N(b) more readily accepts protons. Ignore N(b) is stronger base.
	M2	lp or electrons or electron density on N labelled a: <u>delocalized into_(benzene)_ring</u>	1	QoL
	M3	lp or electrons or electron density on N labelled b: methyl/alkyl groups <u>electron releasing or donating</u> or (positive) inductive effect or push electrons or electron density	1	QoL
9(b)	C ₁₉ H ₂₄ N ₂		1	Any order.
	11		1	

General principles applied to marking CHEM4 papers by CMI+ (June 2013)

It is important to note that the guidance given here is generic and specific variations may be made at individual standardising meetings in the context of particular questions and papers.

Basic principles

- **Examiners should note that throughout the mark scheme, items that are underlined are required information to gain credit.**
- **Occasionally an answer involves incorrect chemistry and the mark scheme records CE = 0, which means a chemical error has occurred and no credit is given for that section of the clip or for the whole clip.**
-

A. The “List principle” and the use of “ignore” in the mark scheme

If a question requires **one** answer and a candidate gives two answers, no mark is scored if one answer is correct and one answer is incorrect. There is no penalty if both answers are correct.

N.B. Certain answers are designated in the mark scheme as those which the examiner should “Ignore”. These answers are not counted as part of the list and should be ignored and will not be penalised.

B. Incorrect case for element symbol

The use of an incorrect case for the symbol of an element should be penalised **once only** within a clip. For example, penalise the use of “h” for hydrogen, “CL” for chlorine or “br” for bromine.

C. Spelling

In general

- The names of chemical compounds and functional groups **must be spelled correctly** to gain credit.
- Phonetic spelling may be acceptable for some chemical terminology.

N.B. Some terms may be required to be spelled correctly or an idea needs to be articulated with clarity, as part of the “Quality of Language” (**QoL**) marking. These will be identified in the mark scheme and marks are awarded only if the QoL criterion is satisfied.

D. Equations

In general

- Equations **must** be balanced.
- When an equation is worth two marks, one of the marks in the mark scheme will be allocated to one or more of the reactants or products. This is independent of the equation balancing.
- State symbols are generally ignored, unless specifically required in the mark scheme.

E. Reagents

The command word “Identify”, allows the candidate to choose to use **either** the name or the formula of a reagent in their answer. In some circumstances, the list principle may apply when both the name and the formula are used. Specific details will be given in mark schemes.

The guiding principle is that a reagent is a chemical which can be taken out of a bottle or container. Failure to identify complete reagents **will be penalised**, but follow-on marks (e.g. for a subsequent equation or observation) can be scored from an incorrect attempt (possibly an incomplete reagent) at the correct reagent. Specific details will be given in mark schemes.

For example, **no credit** would be given for

- the cyanide ion or CN^- when the reagent should be potassium cyanide or KCN;
- the hydroxide ion or OH^- when the reagent should be sodium hydroxide or NaOH;
- the $\text{Ag}(\text{NH}_3)_2^+$ ion when the reagent should be Tollens' reagent (or ammoniacal silver nitrate). In this example, no credit is given for the ion, but credit could be given for a correct observation following on from the use of the ion. Specific details will be given in mark schemes.

In the event that a candidate provides, for example, **both** KCN and cyanide ion, it would be usual to ignore the reference to the cyanide ion (because this is not contradictory) and credit the KCN. Specific details will be given in mark schemes.

F. Oxidation states

In general, the sign for an oxidation state will be assumed to be positive unless specifically shown to be negative.

G. Marking calculations

In general

- A correct answer alone will score **full marks** unless the necessity to show working is specifically required in the question.
- An arithmetic error may result in a one mark penalty if further working is correct.
- A chemical error will usually result in a two mark penalty.

H. Organic reaction mechanisms

Curly arrows should originate either from a lone pair of electrons or from a bond.

The following representations should not gain credit and will be penalised each time within a clip.

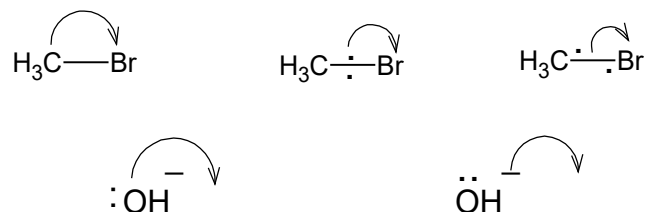

For example, the following would score zero marks

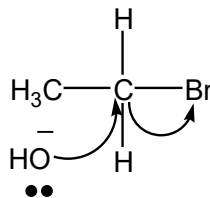

When the curly arrow is showing the formation of a bond to an atom, the arrow can go directly to the relevant atom, alongside the relevant atom or **more than half-way** towards the relevant atom.

In free-radical substitution

- The absence of a radical dot should be penalised **once only** within a clip.
- The use of double-headed arrows or the incorrect use of half-headed arrows in free-radical mechanisms should be penalised **once only** within a clip

In mass spectrometry fragmentation equations, the absence of a radical dot on the molecular ion and on the free-radical fragment would be considered to be two independent errors and both would be penalised if they occurred within the same clip.

I. Organic structures

In general

- Displayed formulae must show all of the bonds and all of the atoms in the molecule, but need not show correct bond angles.
- Bonds should be drawn correctly between the relevant atoms. This principle applies in all cases where the attached functional group contains a carbon atom, e.g. nitrile, carboxylic acid, aldehyde and acid chloride. The carbon-carbon bond should be clearly shown. Wrongly bonded atoms will be penalised **on every occasion**. (see the examples below)
- The same principle should also be applied to the structure of alcohols. For example, if candidates show the alcohol functional group as C – HO, they should be penalised **on every occasion**.
- Latitude should be given to the representation of C – C bonds in alkyl groups, given that CH₃– is considered to be interchangeable with H₃C– even though the latter would be preferred.
- Similar latitude should be given to the representation of amines where NH₂– C will be allowed, although H₂N– C would be preferred.
- Poor presentation of vertical C – CH₃ bonds or vertical C – NH₂ bonds should **not** be penalised. For other functional groups, such as – OH and – CN, the limit of tolerance is the half-way position between the vertical bond and the relevant atoms in the attached group.

By way of illustration, the following would apply.

allowed	allowed	not allowed	not allowed	not allowed
allowed	allowed	allowed	allowed	not allowed

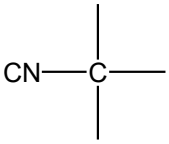
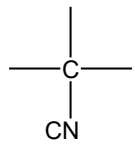
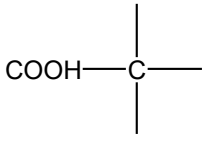
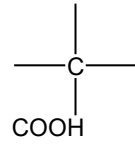
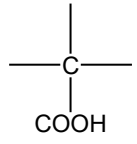
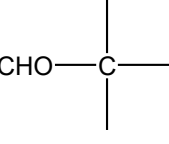
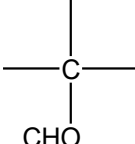
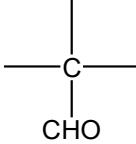
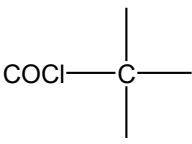
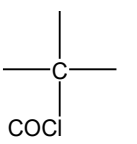
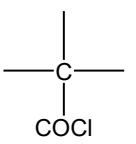
					
not allowed	not allowed	not allowed	not allowed	not allowed	
					
not allowed	not allowed	not allowed	not allowed	not allowed	not allowed

- In most cases, the use of “sticks” to represent C – H bonds in a structure should **not** be penalised. The exceptions will include structures in mechanisms when the C – H bond is essential (e.g. elimination reactions in haloalkanes) and when a displayed formula is required.
- Some examples are given here of **structures** for specific compounds that should **not** gain credit

CH₃COH for ethanal

CH₃CH₂HO for ethanol

OHCH₂CH₃ for ethanol

C₂H₆O for ethanol

CH₂CH₂ for ethene

CH₂.CH₂ for ethene

CH₂:CH₂ for ethane

N.B. Exceptions may be made in the context of balancing equations

- Each of the following **should gain credit** as alternatives to correct representations of the structures.

CH₂ = CH₂ for ethene, H₂C=CH₂

CH₃CHOHCH₃ for propan-2-ol, CH₃CH(OH)CH₃

J. Organic names

As a general principle, non-IUPAC names or incorrect spelling or incomplete names should **not** gain credit. Some illustrations are given here.

but-2-ol	should be butan-2-ol
2-hydroxybutane	should be butan-2-ol
butane-2-ol	should be butan-2-ol
2-butanol	should be butan-2-ol
ethan-1,2-diol	should be ethane-1,2-diol
2-methylpropan-2-ol	should be 2-methylpropan-2-ol
2-methylbutan-3-ol	should be 3-methylbutan-2-ol
3-methylpentan	should be 3-methylpentane
3-mythylpentane	should be 3-methylpentane
3-methypentane	should be 3-methylpentane
propanitrile	should be propanenitrile
aminethane	should be ethylamine (although aminoethane can gain credit)
2-methyl-3-bromobutane	should be 2-bromo-3-methylbutane
3-bromo-2-methylbutane	should be 2-bromo-3-methylbutane
3-methyl-2-bromobutane	should be 2-bromo-3-methylbutane
2-methylbut-3-ene	should be 3-methylbut-1-ene
difluorodichloromethane	should be dichlorodifluoromethane