

The figure shows the energy changes which occur during one stage of cellular respiration. A, B, C and D are intermediate compounds.

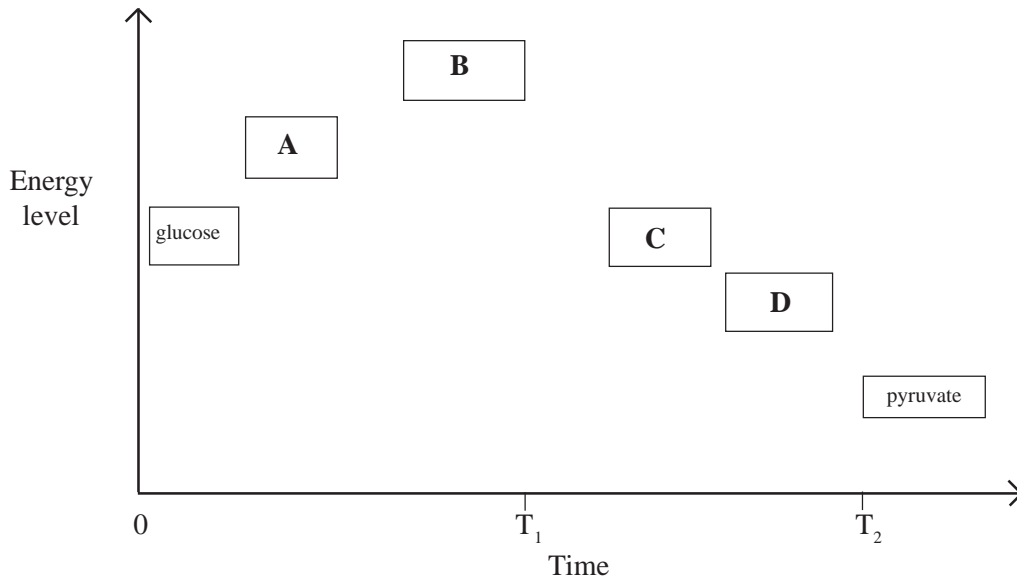

(a) State where in the cell this stage would take place.

..... [1]

(b) Suggest an explanation for the energy changes between,

(i) Time 0 to T₁:

..... [2]

(ii) Time T₁ to T₂:

..... [2]

(c) In aerobic conditions what will be the immediate fate of the pyruvate?

..... [2]

(d) Outline the role of coenzymes in aerobic respiration.

.....

The diagram below shows the structure of ATP.

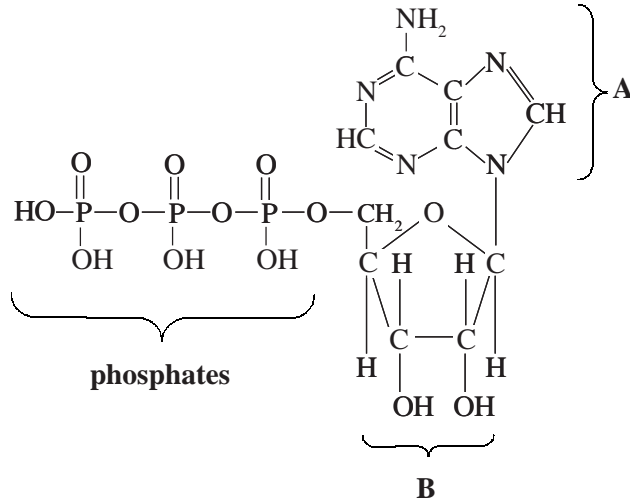

(a) Name each of the components:

(i) A: [1]

(ii) B: [1]

(b) The table shows the relative energy levels of common phosphate-containing metabolites

Metabolite	Relative Energy
Creatine phosphate	very high
Adenosine triphosphate Adenosine diphosphate Glucose-1-phosphate	Intermediate
Glucose-6-phosphate	Low

(i) Suggest why ADP and ATP are effective energy carrier molecules.

.....

[2]

(ii) Suggest why high levels of creatine phosphate are found in striated muscle tissues.

.....

[2]

ATP is produced in both chloroplasts and mitochondria.

The table below compares the process of ATP production in these organelles. Complete the table with a tick (✓) in the appropriate box if the statement is true for ATP production in each organelle and a cross (×) if the statement is incorrect.

Statement	Chloroplast	Mitochondrion
Electrons are excited by photons		
Electrons pass through carriers		
Involves oxidative photophosphorylation		
ATP produced from ADP and phosphate		
Occurs in day and night		

[5]

Cyanide is a metabolic poison. Cyanide ions (CN⁻) bind to cytochrome oxidase which is the final carrier in the electron transport chain. This is shown in the figure below.

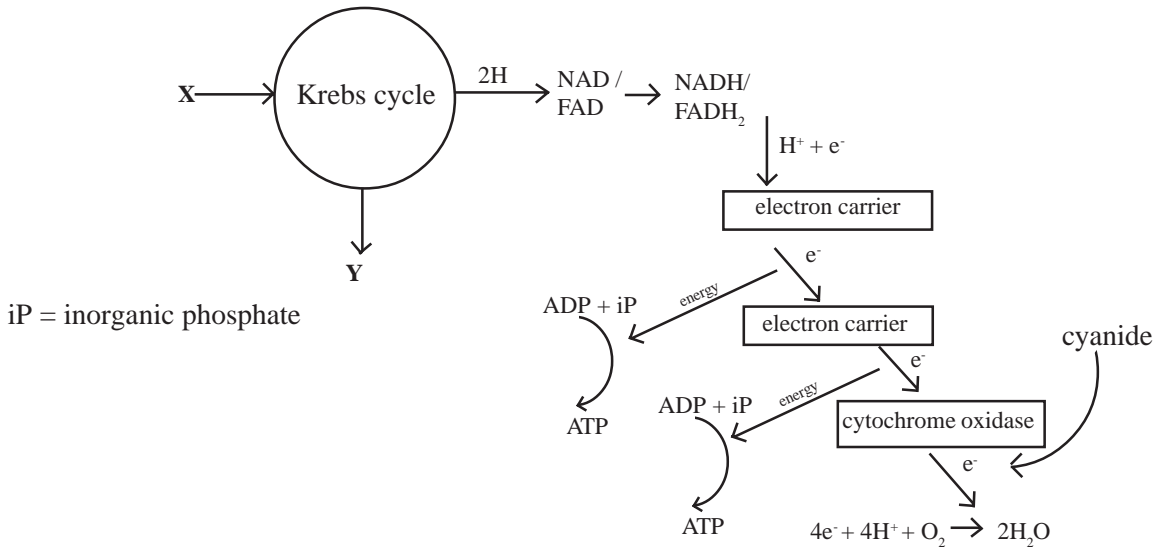

(a) Name substances X and Y.

X:

Y:

[2]

(b) State precisely where in the cell:

(i) The Krebs cycle occurs. [1]

(ii) electron carriers are situated. [1]

(c) Explain the term 'coupled redox reaction'.

.....

[3]

(d) Suggest why cyanide poisoning victims suffer from severe ATP shortage.

.....

[2]

The diagram shows the sequence of events involved in glycolysis and Krebs cycle.

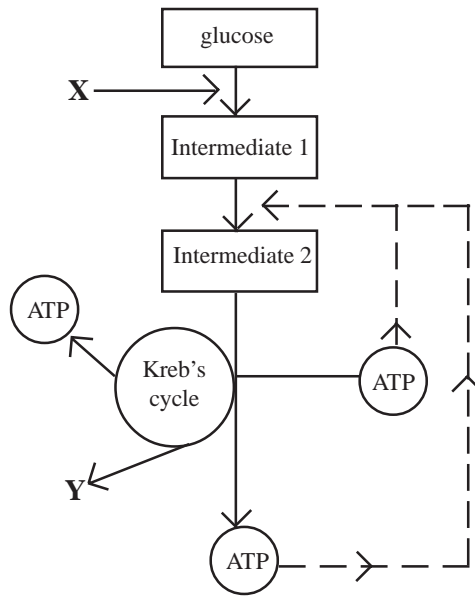

(a) Name the substances X and Y.

X:

Y:

[2]

(b) State where in the cell the processes of glycolysis and Krebs cycle occur.

glycolysis:

Krebs cycle:

[2]

(c) Use the information in the diagram to explain the term 'feedback inhibition'.

.....
.....
.....

[3]

The equation shows some of the stages in the process of glycolysis.

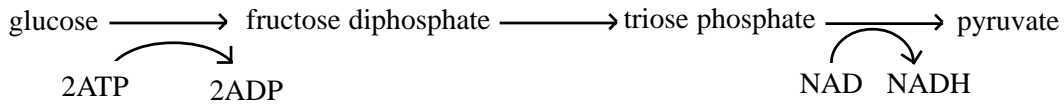

(a) Where in the cell does glycolysis occur?

..... [1]

(b) Explain why ATP molecules are used in the first stage of glycolysis.

..... [1]

(c) What type of chemical reaction is involved in the conversion of triose phosphate to pyruvate?

..... [1]

(d) How is NADH reoxidised in anerobic conditions in:

(i) animals?..... [1]

(ii) yeast ?..... [1]

(e) Outline the process of oxidative phosphorylation.

.....
.....
..... [3]

The table below summarises the process of cellular respiration. Complete the table by filling in the gaps.

Stage	Site	Oxygen Needed?	What Happens?
Glycolysis			Glucose is converted to Hydrogen is removed and is passed to the electron carriers.
	Matrix of Mitochondria	Yes	Pyruvate enters mitochondrion, is decarboxylated, dehydrogenated and combines with coenzyme A to give acetyl coenzyme A. The hydrogen which is removed is passed to the electron carriers.
			A cyclical series of reactions during which hydrogen is passed to the electron carriers, carbon dioxide is removed and a starting reactant is regenerated.
Electron Transfer Chain		Yes	The hydrogen from the respiratory reactions is split to release electrons. These pass through carriers and generate The hydrogen reforms and is combined with oxygen to release water.

[9]

Read the following passage and answer the questions which follow.

The TCA cycle is also known as the citric acid or Krebs cycle. Pyruvate, synthesised in glycolysis is converted into acetylcoenzyme A which enters the TCA cycle. The rate at which the TCA cycle proceeds is carefully regulated. If ATP begins to accumulate, the rate is slowed. One such mechanism involves the allosteric inhibition by ATP of the enzyme isocitrate dehydrogenase.

(a) Outline how pyruvate is produced in glycolysis.

.....
.....
.....

[3]

(b) State where in the cell glycolysis and the TCA cycle take place.

(i) glycolysis:

[1]

(ii) TCA cycle:

[1]

(c) Explain how allosteric inhibition can be used to control the rate of the cycle.

.....
.....
.....
.....
.....

[3]

(d) Outline the fate of pyruvic acid in yeast under anaerobic conditions.

.....
.....
.....
.....

[4]

Suggest explanations for the following:

(a) Ethanol accumulates in the roots of plants which have been overwatered.

.....
.....
.....

[3]

(b) Krebs cycle reactions continue even if glycolysis stops.

.....
.....
.....

[2]

(c) Lactic acid accumulates in the body of a person who exercises vigorously.

.....
.....
.....
.....
.....

[4]

The diagram below shows some of the stages in cellular respiration in humans.

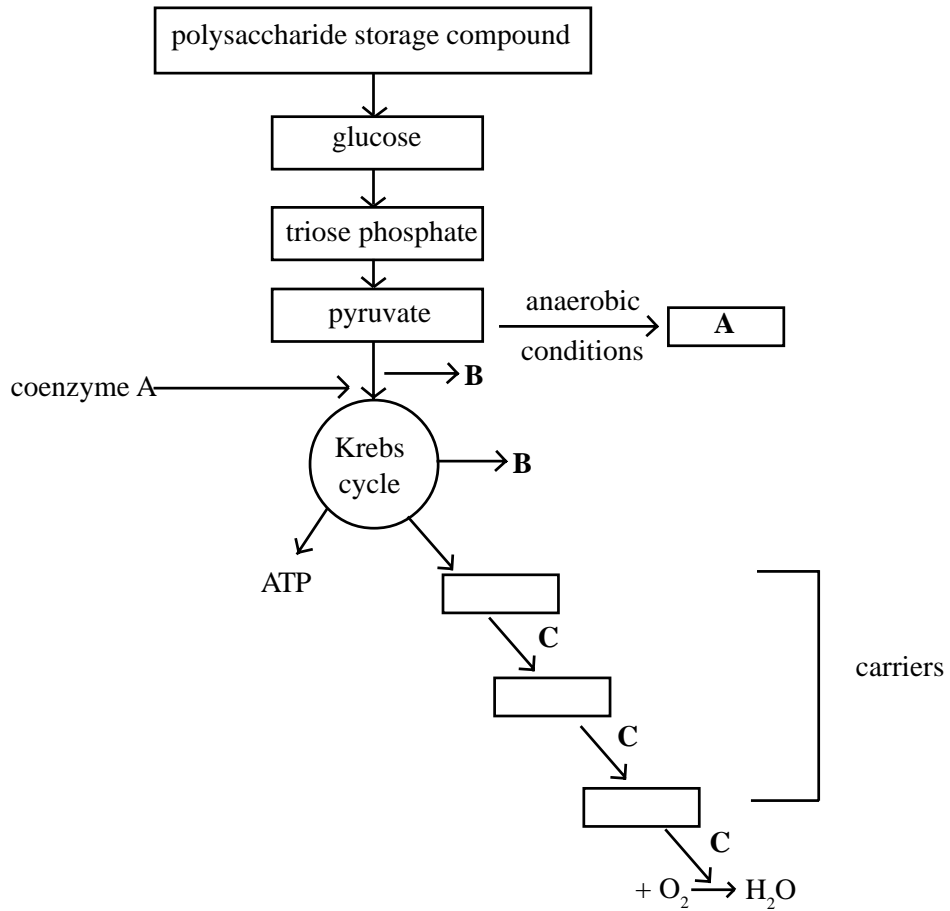

(a) Identify the following components:

- (i) A. [1]
- (ii) B. [1]
- (iii) C. [1]

(b) State the significance of the following components:

- (i) phosphorylase enzymes. [1]
- (ii) dehydrogenase enzymes. [1]

(c) Briefly explain why anaerobic respiration produces much less ATP than aerobic respiration.

.....

[4]

Individuals who become deficient in the vitamin B complex may suffer from a lack of energy. The table outlines the functions of some of the vitamin B complex.

Vitamin	Function
Niacin (Nicotinic acid)	Part of the NAD and NADP coenzymes
Riboflavin (B ₂)	Part of the prosthetic group FAD
Pantothenic acid	Part of coenzyme A

(a) (i) What is meant by the term 'coenzyme'?

.....

.....

.....

[2]

(ii) What is meant by the term 'prosthetic group'?

.....

[1]

(b) Suggest why individuals who are deficient in B complex vitamins may suffer from a lack of energy.

.....

.....

.....

.....

.....

.....

[4]

The equation shows one part of the stages of respiration.

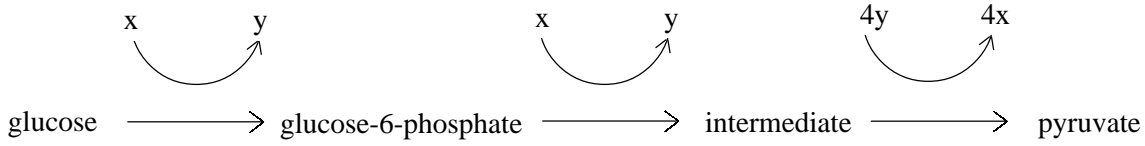

(a) Name this stage.

..... [1]

(b) Identify X and Y:

X..... [1]

Y..... [1]

(c) State:

(i) the name of one process by which glucose enters cells.

..... [1]

(ii) where in the cell this stage occurs.

..... [1]

(d) Suggest:

(i) why glucose is first converted into glucose-6-phosphate.

..... [1]

(ii) why this stage is vital in red blood cells.

..... [2]

The amino groups of unwanted amino acids are toxic to the body and so these amino groups are removed from the amino acids as ammonia.

(a) (i) Where does this process mainly occur in the body?

..... [1]

(ii) What is the name given to the process of forming ammonia from amino acids?

..... [1]

(iii) Explain why mammals do not excrete the ammonia directly as their main nitrogenous end product.

..... [2]

The diagram below shows the Ornithine Cycle which is responsible for making urea from ammonia.

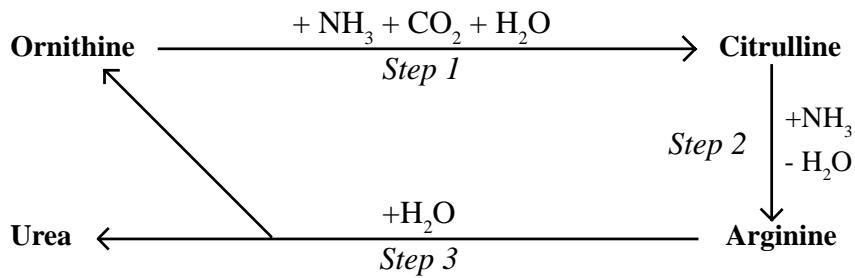

(b) (i) In which organ of the body does this process mainly occur? [1]

(ii) Where does the CO_2 come from in step 1?

..... [1]

(iii) Why is the amino acid ornithine referred to as a “carrier substance”?

..... [2]

(iv) What type of reaction is step 3? [1]

(v) Why is urea a more suitable excretory end product than ammonia, in mammals?

..... [2]

When substances cross biological membranes energy is either released or used.

(a) Distinguish between membrane transport by diffusion and membrane transport by active transport.

.....

.....

.....

.....

[4]

Chemiosmosis is the process in which energy released when a substance moves along a gradient is used to synthesise ATP. The diagram below illustrates this mechanism.

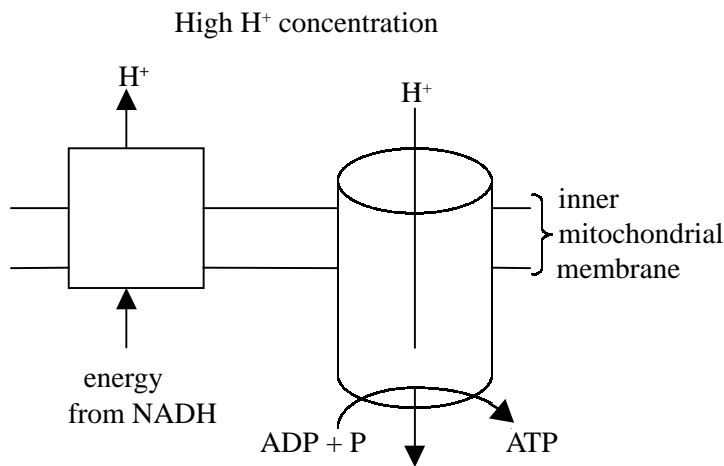

(b)(i) What name is given to the chemical reaction that synthesizes ATP?

.....

[1]

(ii) What type of pumps are the electron chain carriers? Explain why.

Type:

[1]

Why:

[1]

(iii) What are the functions of ATPase?

.....

.....

.....

.....

[3]

The respiratory quotient can yield information about the nature of the substrate being used for respiration and the type of metabolism that is occurring.

(a) Define the term 'respiratory quotient'.

.....
.....

[2]

The following equation shows the aerobic respiration of the oil triolein(olive oil).

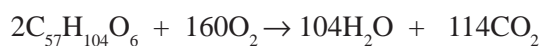

(b)(i) Calculate the respiratory quotient for the respiration of triolein. Show your working.

Answer [2]

(ii) When the respiratory quotient of a human is measured the value is usually between 0.7 and 1.0. Explain why this is so.

.....
.....
.....
.....

[3]

The apparatus below can be used to demonstrate whether germinating peas respire purely carbohydrate or a mixture of carbohydrate and fat.

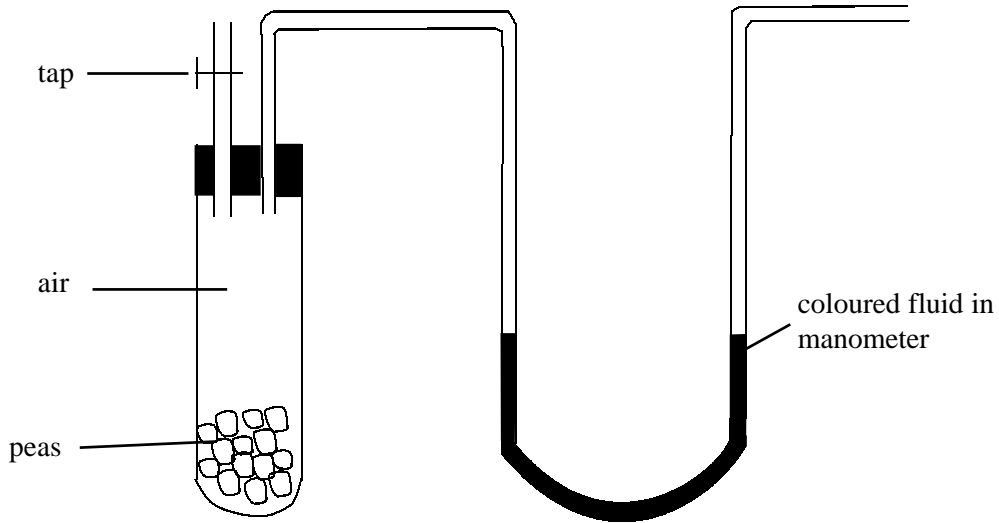

(c) (i) What would happen if the seeds were respiring:

carbohydrate only.
.....

carbohydrate and fat?
.....

[2]

(ii) Describe how you would use the apparatus to determine which substrates the germinating peas were using.

.....
.....
.....
.....

[3]

(iii) If the peas were only respiring carbohydrates which metabolic processes would they be using?

.....

[1]

Study the flow diagram below which refers to various metabolic pathways, and then answer the questions.

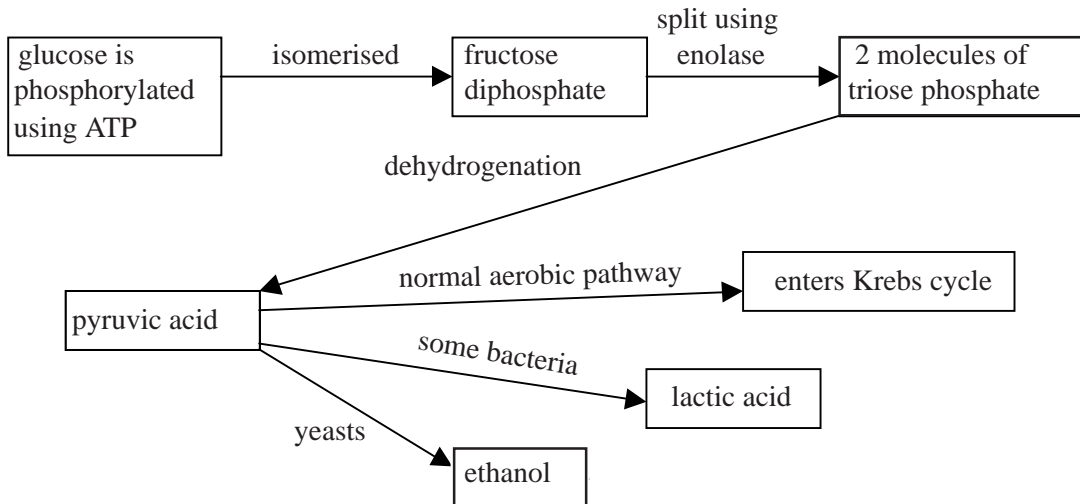

(a) (i) Why is it necessary to phosphorylate glucose using ATP?

.....
.....
[2]

(ii) What is isomerisation?

.....
.....
[1]

(iii) Suggest a reason for the isomerisation of glucose to fructose.

.....
.....
[1]

(iv) What is the importance of the dehydrogenation step in the pathway?

.....
.....
[2]

(b)(i) Explain why yeasts may sometimes respire to produce alcohol but at other times just produce carbon dioxide and water.

.....
.....
.....
.....
.....

[4]

(ii) Why do some bacteria, such as Lactobacilli produce lactic acid?.

.....
.....
.....

[2]

(iii) State one commercial use of Lactobacilli.

.....

[1]

(b) Fluoride is an inhibitor of the enzyme enolase. Why is it advantageous to add fluoride to toothpaste and drinking water?

.....
.....
.....

[2]

The respiratory quotient (RQ) is useful since it will indicate the type of metabolism being carried out by an organism. Carbohydrate respiration gives an RQ of 1.0, protein respiration an RQ of 0.9 and fat respiration an RQ of 0.7.

(a) (i) What is meant by the term 'respiratory quotient'?

.....
..... [2]

(ii) Why do animals usually have an RQ between 0.7 and 1.0?

.....
..... [2]

(iii) When may organisms have an RQ less than 0.7? Give an example.

When:

Example: [2]

The graph below shows the RQs of barley seeds and castor oil seeds during germination.

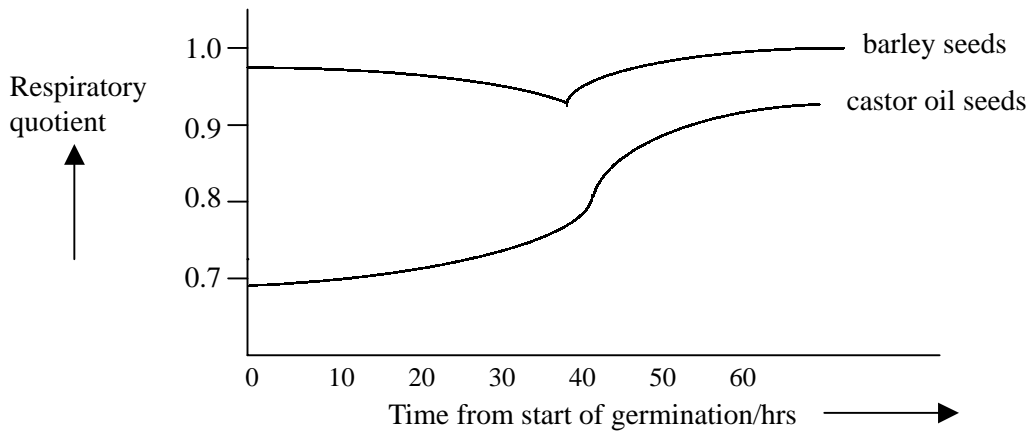

(b) (i) Explain the different values for the RQs of barley and castor oil over the first 30 hours.

.....
..... [2]

(ii) Explain the changes in the RQ of the two sets of seeds after 40 hours.

.....
..... [2]

The diagram below shows stages in the deamination of the amino acid alanine.

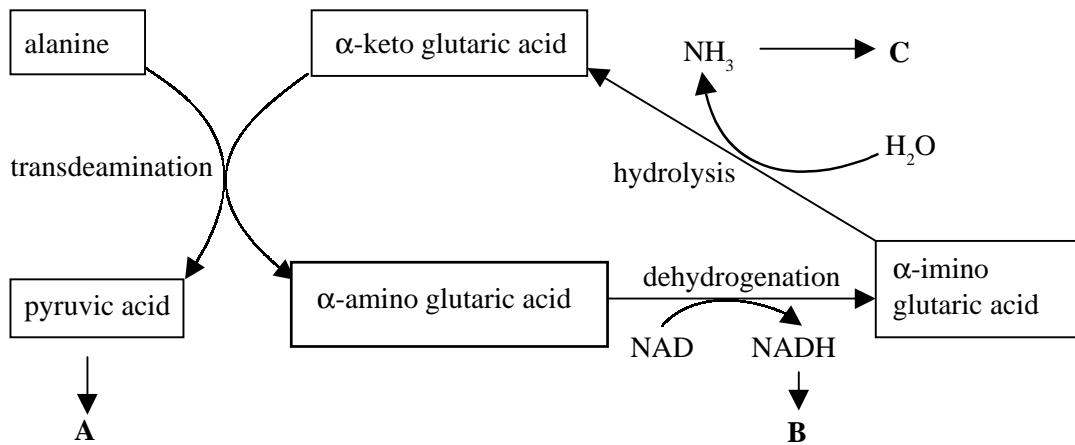

(a) (i) Why is deamination necessary?

.....
 [2]

(ii) Where does deamination occur in the human body?

..... [1]

(b) (i) Explain why deamination can be considered a respiratory process as well as an excretory process.

.....

 [3]

(ii) Explain what happens to the:

pyruvic acid at A:
 [2]

NADH at B:
 [2]

NH₃ at C:
 [2]

Read through the following passage about cellular respiration and then complete it by writing the most appropriate word or words in the spaces.

During glucose metabolism the glucose is first made metabolically mobile by
using the energy rich substance The mobilised glucose is then isomerised to
make..... which is then split with the enzyme enolase to yield two molecules of
..... This eventually undergoes dehydrogenation yielding the reduced coenzyme
..... and pyruvic acid. This overall process is calledand
occurs in the The reduced coenzyme enters an organelle called a
and is reoxidised on the membrane by the to form
.....molecules of ATP. Water is produced as a byproduct as the.....
are removed by combination with under the influence of the enzyme
oxidase. The pyruvic acid is converted to acetyl-coenzyme A in the reaction and is then
metabolised in the pathway.

For each of the following statements say whether it is **true** or **false** and give an explanation for your answer.

(a) Proteins and amino acids are only respired in humans during times of extreme starvation.

.....
.....
.....
.....
.....
.....

[5]

(b) The camel stores and respire fat rather than carbohydrate because it lives in a desert environment.

.....
.....
.....
.....
.....

[4]

(c) Yeast cells always produce ethanol when respiring.

.....
.....
.....
.....

[3]