

(a) Show how two molecules of glucose below join together to form a disaccharide.

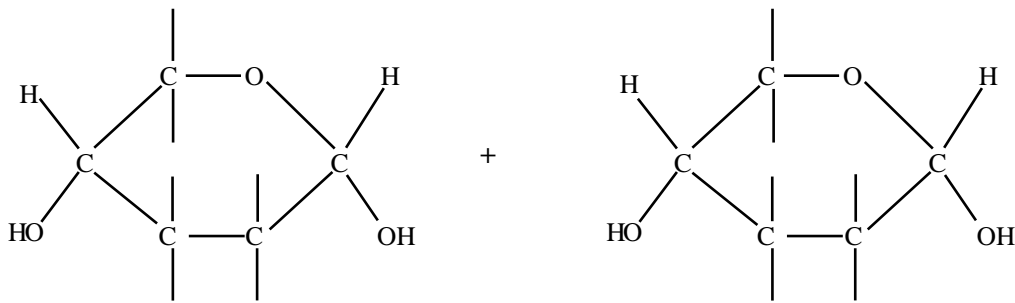

[2]

(b) What is the name given to this type of reaction?

..... [1]

(c) What is the name of the reverse reaction?

..... [1]

(d) Glycogen is a complex storage polysaccharide. In which organ is it mainly stored in vertebrates?

..... [1]

(e) A solution which tested negative for reducing sugars was thought to contain sucrose and protein. Describe how you would find out whether this was so.

.....
.....
.....
.....
.....
.....

[6]

The diagrams below show two different forms of glucose

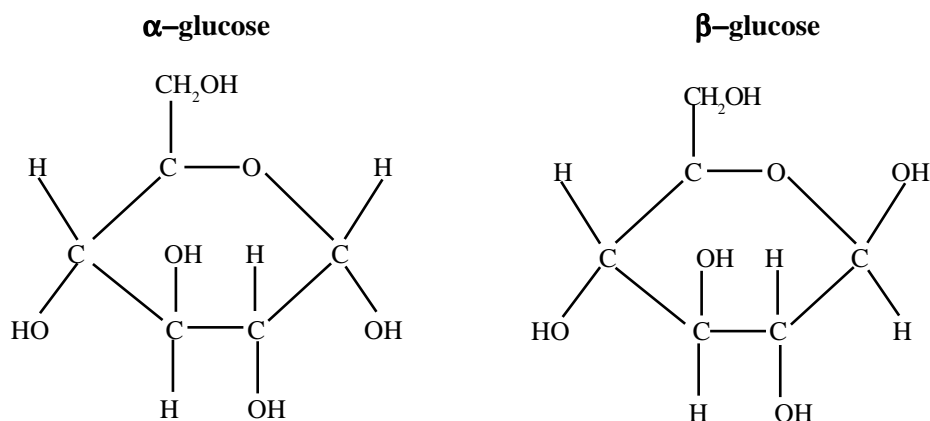

(a) What term is used to describe these two forms?

..... [1]

(b) How do the two forms of glucose differ from one another?

..... [1]

(c) Why is it important to have these two differing forms?

.....
 [2]

(d) What kinds of bonds occur in carbohydrates?

..... [1]

Stearic acid is a saturated fatty acid with the formula $C_{17}H_{35}COOH$. Oleic acid is an unsaturated fatty acid with the formula $C_{17}H_{33}COOH$.

(a) (i) What do the terms saturated and unsaturated mean?

.....
.....
[2]

(ii) In what ways do the properties of saturated and unsaturated fats differ?

.....
.....
[2]

(b) Why are lipids useful as storage molecules?

.....
.....
.....
.....
[4]

(c) (i) Name the parts of the triglyceride shown below by writing in the boxes and completing the label.

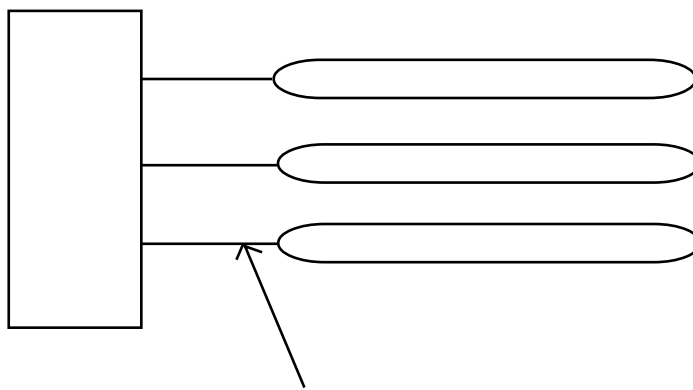

..... [3]

(ii) In what way would the structure of a phospholipid differ from this triglyceride?

..... [1]

(a) Describe the structure of a phospholipid.

.....
.....
.....

[3]

(b) (i) Show, using a labelled diagram, how phospholipids are arranged in a biological membrane.

[2]

(ii) Explain why the molecules arrange themselves in this way.

.....
.....

[2]

(c) Give two uses of lipids, other than storage.

.....
.....

[2]

(d) Describe a test you would carry out to determine the presence of fat in a sample solution.

.....
.....

[2]

The diagram below shows the general structure of two molecules of amino acid.

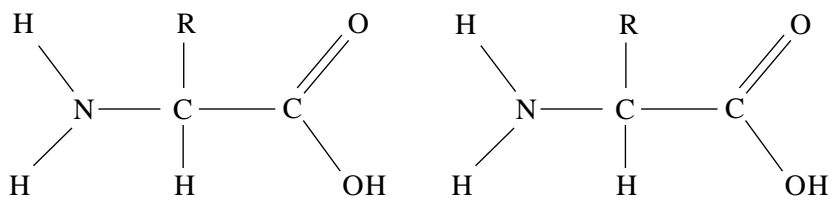

(a) Using the diagram above show how the two amino acids join to make a dipeptide. [3]

(b)(i) What does the “R” represent?

..... [1]

(ii) Give an example of an “R” group.

..... [1]

(iii) What is the name of the bond that links two adjacent amino acids?

..... [1]

(c) “Amino acids are amphoteric”. What does this mean?

.....
..... [1]

Proteins can exist as primary, secondary, tertiary or quaternary structures.
 The diagram below shows one of these protein structures.

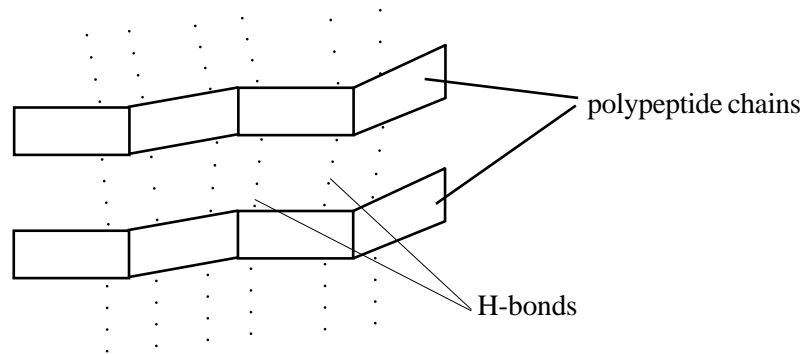

(a) What is the name given to this structure?

..... [1]

(b) What gives this protein structure its high tensile strength?

..... [1]

(c) What is meant by tertiary protein structure?

.....
 [3]

(d) Name two types of bond which hold tertiary protein structure together.

.....
 [2]

(e) Name one common protein which has a quaternary protein structure.

..... [1]

(f) Describe how you would carry out a test to detect the presence of protein in an unknown sample solution.

.....

 [3]

The diagram represents part of a nucleic acid molecule.

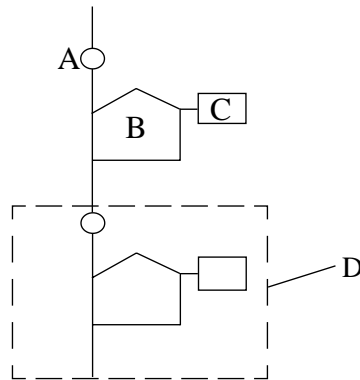

(a) Label the parts A, B, C and D.

- A:
- B:
- C:
- D:

[4]

(b) DNA bases are cytosine (C), adenine (A), guanine (G) and thymine (T).

(i) Using this information explain the term 'complementary base pairs'.

.....

[2]

(ii) State three ways in which RNA differs from DNA.

- 1.....
- 2.....
- 3.....

[3]

(a) The table below refers to various carbohydrates and to their molecular structure. If a feature is correct place a tick (✓) in the box, and if it is incorrect place a cross (✗) in the box.

	monosaccharide	disaccharide	polysaccharide
ribose			
glucose			
maltose			
starch			
lactose			
glycogen			
cellulose			

[7]

(b) State two structural differences between starch and cellulose.

1.
.....
2.
.....

[2]

The diagram below shows part of a double-stranded DNA molecule.

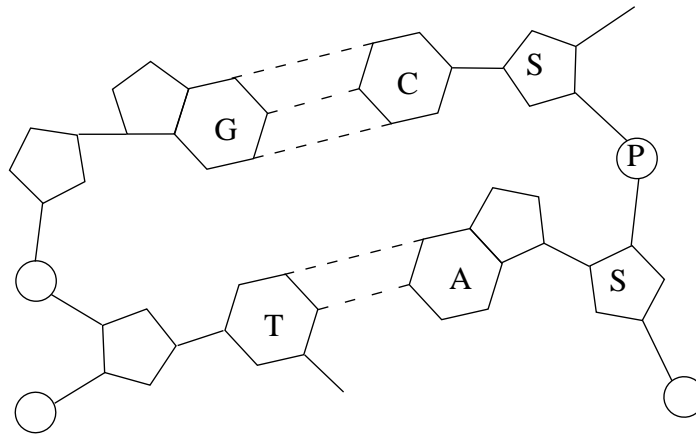

(a) (i) Name parts S, P, G, C, T and A.

S: P: G:

C: T: A:

[6]

(ii) Name the type of bond present between G and C and S and S?

G - C:

[1]

S - S:

[1]

(b) Describe the role of each of the following in metabolism:

(i) ATP.

.....

.....

[2]

(ii) NAD.

.....

.....

[2]

(iii) Co-enzyme A.

.....

.....

[2]

The carbohydrate below has been formed from two glucose molecules.

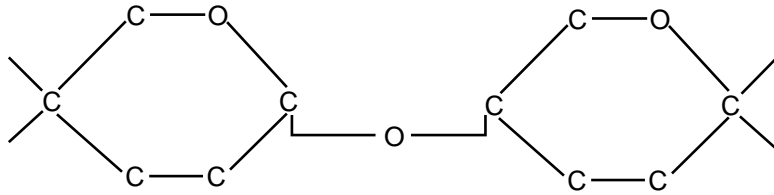

(a) What is this type of carbohydrate called?

..... [1]

(b) What is the name of the chemical bond which joins these two hexose units together?

..... [1]

(c) What is the chemical reaction in which one or more hexose units are joined together?

..... [1]

(d) State one function of the carbohydrate shown above in living cells.

..... [1]

(e) (i) Draw a diagram to show how the two glucose molecules would have been bonded when forming part of a cellulose fibril.

[1]

(ii) Name the type of bond involved.

..... [1]

(a) The diagram illustrates a common food test.

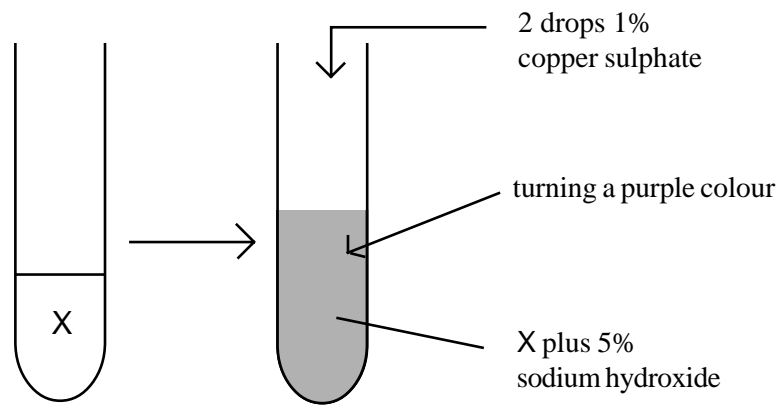

(a) Identify substance X

..... [1]

(b) Describe a Benedicts test to detect the presence of glucose in a sample solution.

.....
.....
..... [3]

(c) The concentration of glucose in solutions can be measured using the glucose oxidase technique.

The solution to be tested is incubated with glucose oxidase and then with peroxidase and an indicator which changes colour when oxidised in the reaction. Peroxidase breaks down the hydrogen peroxide formed by the glucose oxidase, releasing oxygen which changes the colour of the indicator.

The intensity of the colour produced is directly proportional to the concentration of glucose in the solution.

Describe how you would use this method to compare the concentration of glucose in a test solution to a known standard concentration of glucose solution.

.....
.....
.....
..... [4]

The diagram below shows part of a cellulose molecule.

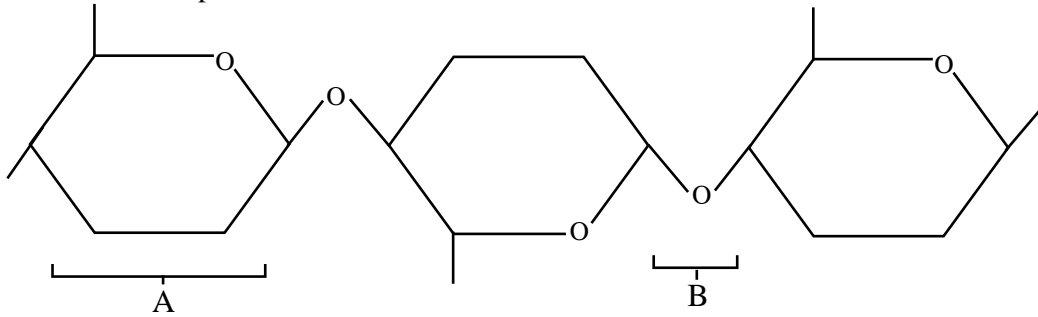

(a) Identify parts A and B.

A: [1]

B: [1]

(b) What reaction is involved in the formation of bond B?

..... [1]

(c) Give one function of cellulose in living organisms.

..... [1]

(d) The table below refers to certain chemical substances. If a statement is correct place a tick (✓) in the appropriate box and if a statement is incorrect place a cross (×) in the appropriate box.

	SUBSTANCE		
	Starch	Protein	DNA
Only contains C, H, and O			
Contains nitrogen			
Positive when boiled with Benedicts reagent.			
Hydrolysed to smaller units during digestion			
Contains uracil			

[5]

The diagram below shows part of the cell membrane

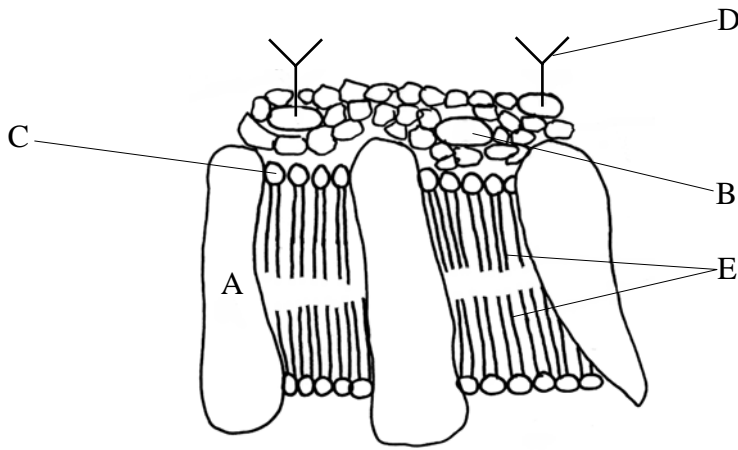

(a) Which two structures would release amino acids on hydrolysis?

1.
 2.
- [1]

(b) Identify components E.

.....

[2]

(c) (i) Identify structure D.

.....

[1]

(ii) Describe the composition of structure D.

.....

[1]

(iii) State two functions of structure D.

- 1:
 - 2:
- [2]

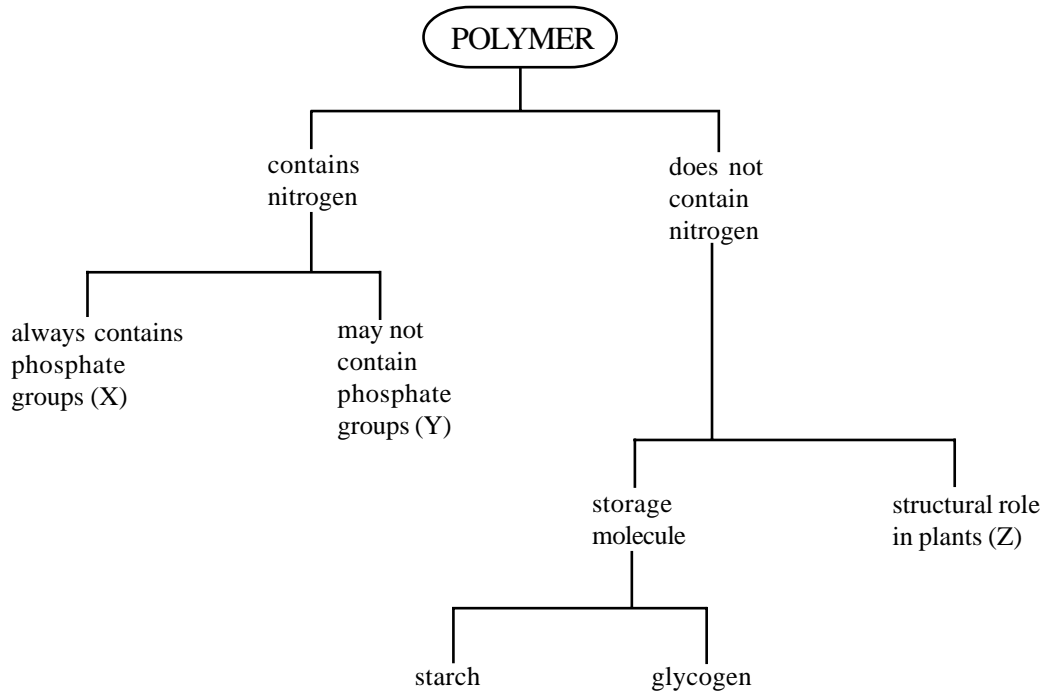

(a) Identify X, Y and Z.

- X: [1]
- Y: [1]
- Z: [1]

(b) Starch is a mixture of two polymers. Name them and say how they differ structurally from each other.

- Names: and [2]
- Difference: [1]

(c) Cysteine is a sulphur containing amino-acid. Suggest the significance of this in:

- (i) protein structure.
.....
..... [2]
- (ii) protein properties.
.....
..... [2]

The diagram below shows a part of a cell membrane.

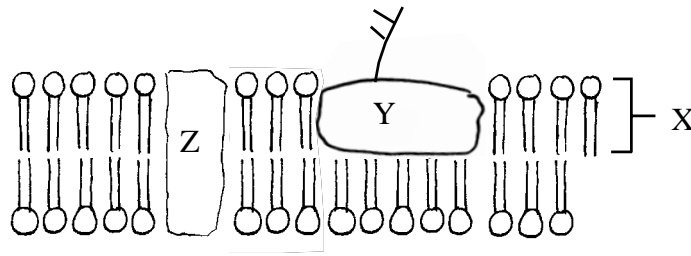

(a) Label X, Y and Z.

X:

Y:

Z:

[3]

(b) State one function of:

Y:

Z:

[2]

(c) The following table refers to the functions of some of the molecules involved in the cell surface membrane. If a function is correct place a tick (✓) in the appropriate box if it is incorrect place a cross (✗) in the appropriate box.

	Phospholipid	Protein	Carbohydrate
Act as enzymes			
Allows passage of water soluble substances			
Involved in cell recognition			

[3]

The diagram shows the structure of a phospholipid molecule. A phospholipid is made from several different chemical components.

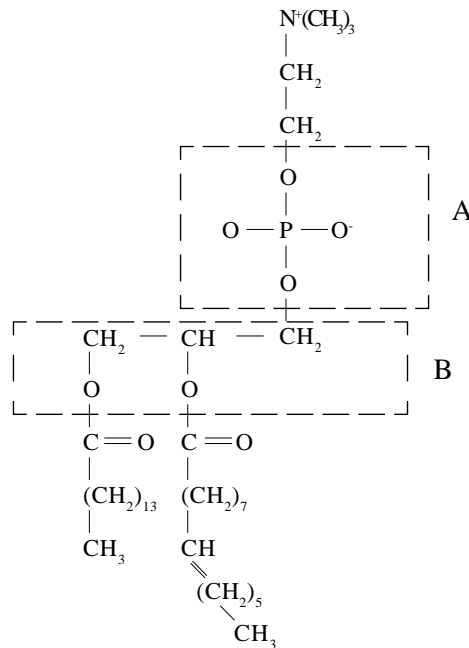

(a) Identify parts A and B.

A

B

[2]

(b) Draw a circle round the portion of the phospholipid which represents a saturated fatty acid.

[1]

(c) State one function of essential fatty acids.

.....

[1]

(d) State and describe one condition associated with a deficiency of:

(i) Vitamin A.

.....

.....

[2]

(ii) Vitamin D.

.....

.....

[2]

The diagram shows one type of protein structure.

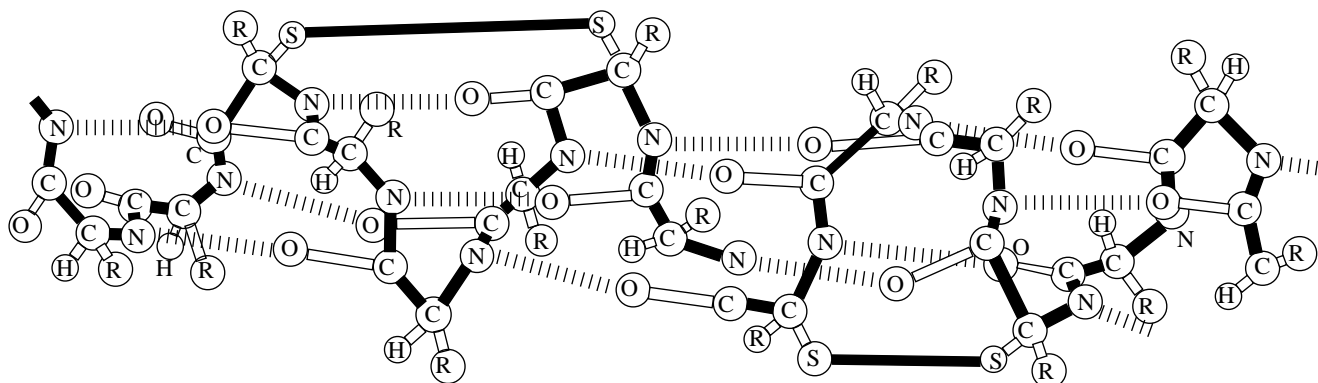

(a) (i) What name is given to this type of structure?

..... [1]

(ii) Name three types of bond involved in holding this structure together.

1 2 3 [3]

(b) (i) What type of structure do proteins which act as enzymes possess?

..... [1]

(ii) What type of structure does the globin of haemoglobin possess?

..... [1]

(iii) Briefly outline how the molecular structure of haemoglobin is suited to its function.

.....

 [4]

The diagram shows the structure of glycogen and the type of bonds which link the glucose molecules.

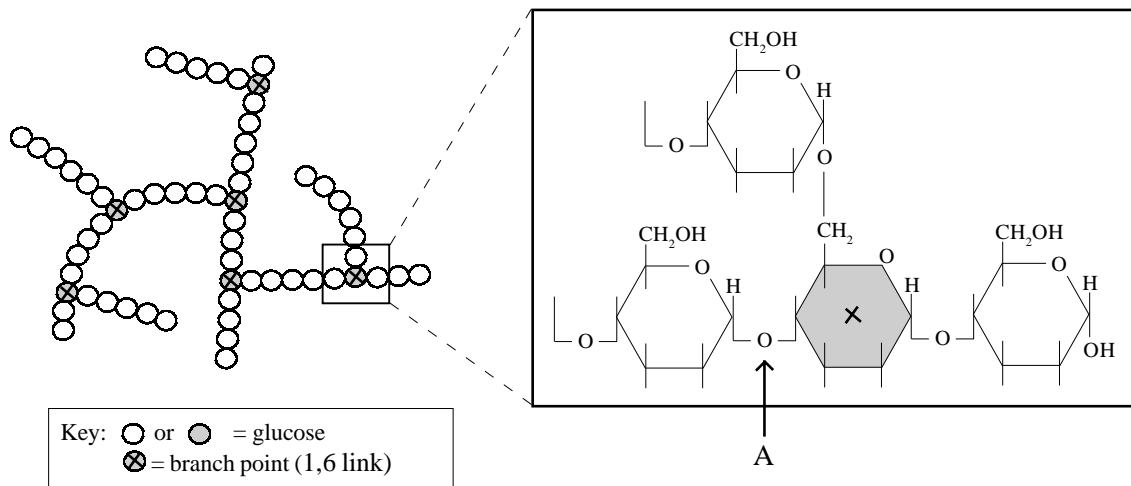

(a) Name the bond formed at point A.

..... [2]

(b) Name one site where glycogen is stored in the body.

..... [1]

(c) Suggest why it is an advantage that the glycogen molecule is branched.

.....

 [2]

(d) State two ways in which a cellulose molecule differs from a glycogen molecule.

1
 2 [2]

(a) Complete the table below by filling in the name of the missing molecules.

Macromolecule	Composition
.....	sugar/base/phosphate
Proteins
Fats	fatty acids
Glycogen
Cellulose

[5]

(b) What factors determine the shape (conformation) of a protein?

.....

.....

.....

[2]

Read through the following account of DNA and then write in the spaces the most appropriate word or words to complete the account.

A DNA molecule is composed of sugars, phosphate groups and four types of base. Within the DNA molecule bases are held together in pairs by bonds. For example, guanine is always paired with and thymine is always paired with Bases in these pairs are said to be to each other. Adenine and guanine are examples of bases, whereas is an example of a pyrimidine base. The two strands of nucleotides are twisted around one another to form a and in each turn of the spiral there are base pairs.

The diagram below shows part of the molecular structure of a nucleic acid.

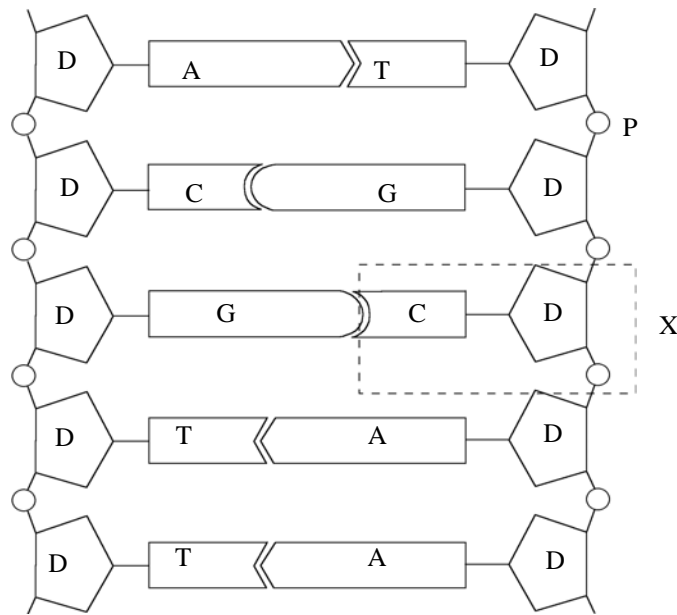

(a)(i) Where in a prokaryotic cell would you expect to find the nucleic acid shown?

..... [1]

(ii) Where in a eukaryotic cell would you expect to find the nucleic acid shown?

..... [1]

(iii) Identify structure X.

..... [1]

(iv) Name parts A, T, C, G, P and D.

A:

T:

C:

G:

P:

D:

[6]

(b) Biochemical analysis of a DNA sample showed that 27% of the nitrogenous bases was cytosine. Calculate the percentage of the bases in the sample which would be thymine. Show your working.

Answer [3]

TOTAL /12 _____