

**ENGINEERING
ADMISSIONS ASSESSMENT**
D564/12
Wednesday 31 October 2018
40 minutes
SECTION 2

Candidate number	J						Centre number							
------------------	---	--	--	--	--	--	---------------	--	--	--	--	--	--	--

	d	d					m	m					y	y	y	y
Date of birth			-			-										

First name(s)	
---------------	--

Surname / Family name	
-----------------------	--

INSTRUCTIONS TO CANDIDATES

Please read these instructions carefully, but do not open the question paper until you are told that you may do so. This paper is Section 2 of 2.

A separate answer sheet is provided for this paper. Please check that you have one. You also require a soft pencil and an eraser.

Please complete **both** the answer sheet and this question paper with your candidate number, centre number, date of birth, and name.

This question paper contains 18 multiple-choice questions. There are **no** penalties for incorrect responses, only marks for correct answers, so you should attempt **all** 18 questions. Each question is worth one mark.

For each question, choose the **one** option you consider correct and record your choice on the separate answer sheet. If you make a mistake, erase thoroughly and try again.

You **must** complete the answer sheet within the time limit.

There is space in the question paper for your working or notes, but **no extra paper** is allowed.

Calculators may **NOT** be used in this section.

Please wait to be told you may begin before turning this page.

This question paper consists of 20 printed pages and 4 blank pages.

PV4



This page is intentionally left blank for your working or notes.

1 A man is cycling along a straight horizontal road at a constant speed of 9.00 m s^{-1} .

He passes a boy who is cycling at 5.00 m s^{-1} in the same direction.

When the man is level with the boy, the boy begins to accelerate at a constant rate of 0.800 m s^{-2} .

The boy maintains this constant acceleration and the man continues at constant speed until the boy passes the man.

What is the time interval between the two instances when the man and the boy are level?

A 5.00 s

B 10.0 s

C 22.5 s

D 35.0 s

E 90.0 s

2 Two liquids P and Q can be mixed together in any proportion.

The density of liquid P is ρ_P and the density of liquid Q is ρ_Q .

A volume V_P of liquid P and a volume V_Q of liquid Q are mixed together to produce a volume that is equal to $V_P + V_Q$.

What is the density of the mixture?

A $\frac{\rho_P + \rho_Q}{2}$

B $\frac{\rho_P V_P + \rho_Q V_Q}{V_P + V_Q}$

C $\left(\frac{\rho_P}{V_P} + \frac{\rho_Q}{V_Q}\right)(V_P + V_Q)$

D $\frac{\rho_P V_Q + \rho_Q V_P}{V_P + V_Q}$

E $\frac{\left(\frac{\rho_P}{V_P} + \frac{\rho_Q}{V_Q}\right)}{V_P + V_Q}$

F $\left(\frac{\rho_P}{V_Q} + \frac{\rho_Q}{V_P}\right)(V_P + V_Q)$

- 3 A circuit contains two fixed resistors, X and Y, and a variable resistor W. The power supply has no internal resistance.

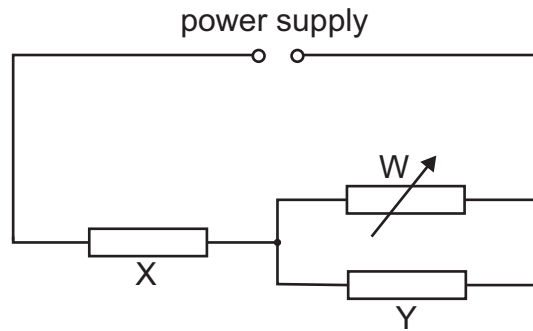

The resistance of W increases.

What happens to the power dissipated in X and in Y?

	<i>power dissipated in X</i>	<i>power dissipated in Y</i>
A	decreases	decreases
B	decreases	stays constant
C	decreases	increases
D	increases	decreases
E	increases	stays constant
F	increases	increases

- 4 The diagram shows two bar magnets, X and Y, held at rest a short distance apart from one another on a smooth horizontal surface. They are aligned as shown in the diagram and both are released at the same time. They move towards each other, collide and coalesce. Just before they collide X has a velocity v to the right.



The mass of X is double the mass of Y.

Which row in the table gives the magnitude and direction of the velocity of the two magnets after the collision?

	<i>magnitude of velocity</i>	<i>direction of velocity</i>
A	0	not applicable
B	$\frac{1}{3}v$	to the left
C	$\frac{2}{3}v$	to the left
D	$\frac{4}{3}v$	to the left
E	$\frac{1}{3}v$	to the right
F	$\frac{2}{3}v$	to the right
G	$\frac{4}{3}v$	to the right

- 5 A stone is suspended from a newtonmeter and the meter reads 3 N. A beaker of water is placed on a top pan balance and the top pan balance reads 400 g.

The stone is lowered into the water so that it is at rest and fully submerged, but not touching the bottom of the beaker. The reading on the newtonmeter is now 2 N and the top pan balance reads Xg.

The stone is detached from the newtonmeter and allowed to rest under water on the base of the beaker. The top pan balance now reads Yg.

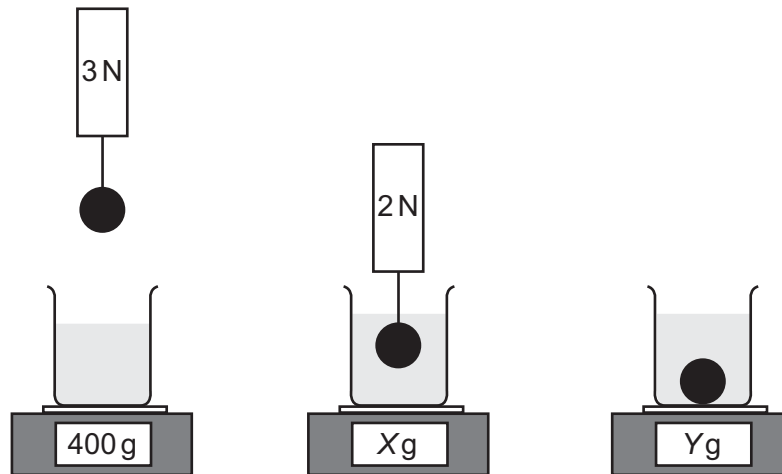

What are the values of X and Y?

(gravitational field strength = 10 N kg^{-1})

	X	Y
A	400	500
B	400	600
C	400	700
D	500	500
E	500	600
F	500	700

- 6 Diagram 1 represents a stationary wave produced by sound in an open-ended tube of length 0.50 m containing a liquid. The speed of the wave in the liquid is 1000 m s^{-1} .

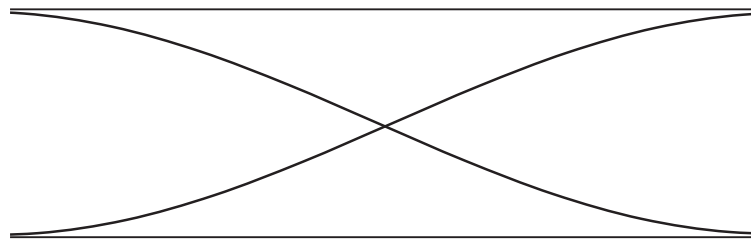

diagram 1

Diagram 2 is a displacement–time graph representing a progressive sound wave with the same frequency in the same liquid.

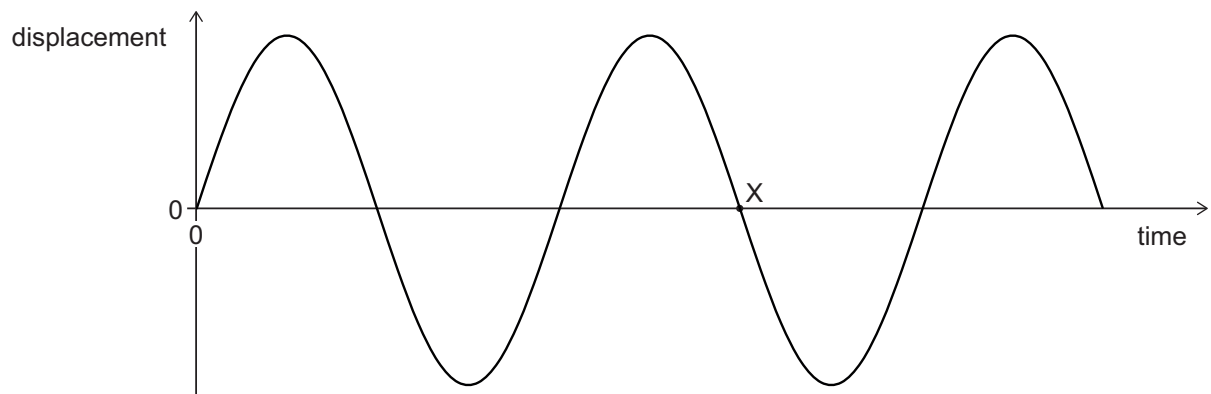

diagram 2

What is the value of the time at point X on the graph?
(End effects of the stationary wave can be ignored.)

- A $2.5 \times 10^{-4} \text{ s}$
- B $3.75 \times 10^{-4} \text{ s}$
- C $5.0 \times 10^{-4} \text{ s}$
- D $7.5 \times 10^{-4} \text{ s}$
- E $1.0 \times 10^{-3} \text{ s}$
- F $1.5 \times 10^{-3} \text{ s}$

- 7 A tennis ball travelling at a speed of 30 m s^{-1} hits a racket elastically with a kinetic energy of 27 J.

The racket applies a variable force to the tennis ball for a time of 4.0 ms as shown.

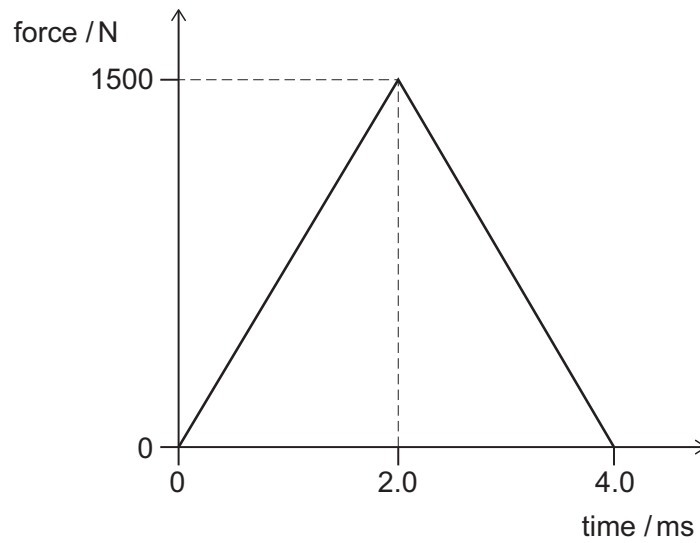

The ball moves away in the opposite direction to its initial motion.

With what speed does the ball leave the racket?

(Assume that resistive forces are negligible.)

- A 20 m s^{-1}
- B 28 m s^{-1}
- C 32 m s^{-1}
- D 50 m s^{-1}
- E 70 m s^{-1}
- F 80 m s^{-1}
- G 100 m s^{-1}
- H 130 m s^{-1}

- 8 A painter of mass 74 kg stands on a uniform wooden plank of length 2.5 m and of mass 24 kg. The painter stands at the middle of the plank. The plank rests on two supports. Support P is 0.25 m from one end of the plank and support Q is 0.75 m from the other end. A pot of paint of mass 5.0 kg is 0.80 m from the centre of mass of the painter.

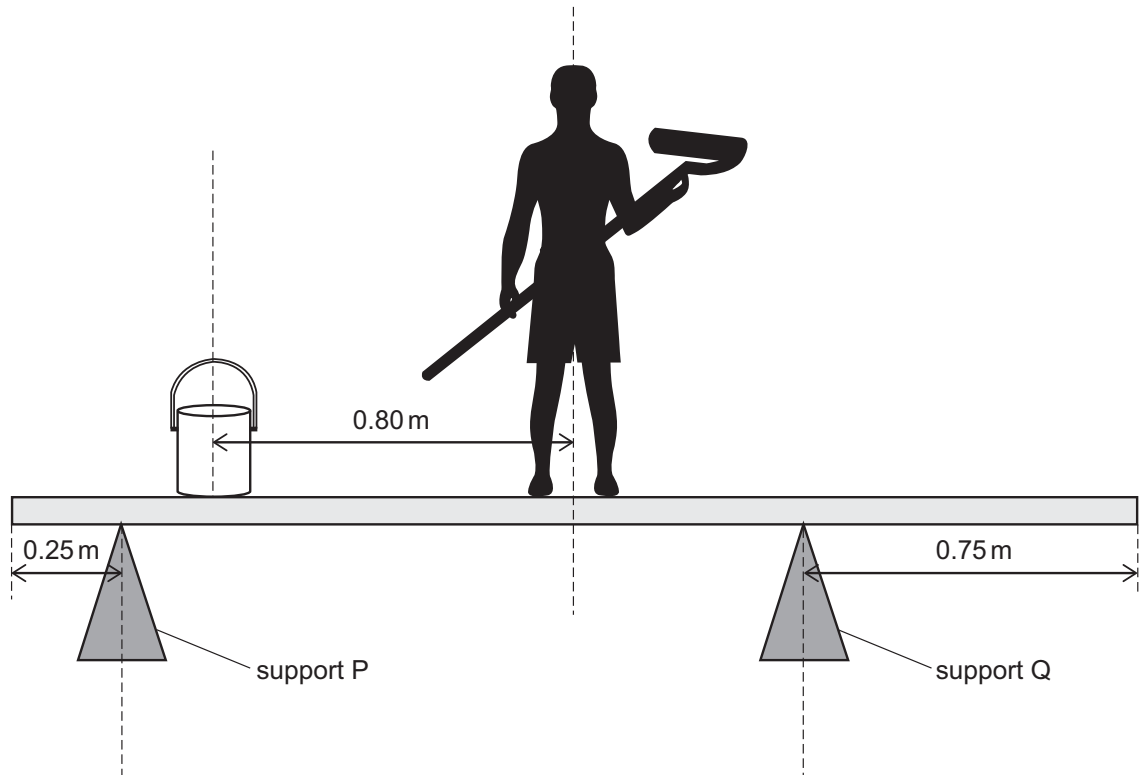

What is the force exerted by support Q on the plank?

(gravitational field strength = 10 N kg^{-1})

- A 50 N
- B 51.5 N
- C 66 N
- D 177 N
- E 500 N
- F 515 N
- G 660 N
- H 1770 N

- 9 The circuit shown in the diagram contains six resistors and an ideal digital voltmeter.

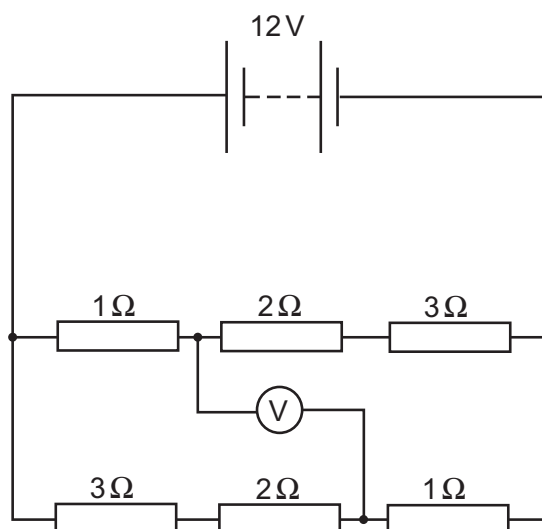

What is the reading on the voltmeter?

- A 0V
- B 2V
- C 4V
- D 6V
- E 8V
- F 10V
- G 12V

- 10 Four identical light springs are connected together using a light rod. A load of mass m is suspended from the system so that the rod is horizontal, as shown in the diagram.

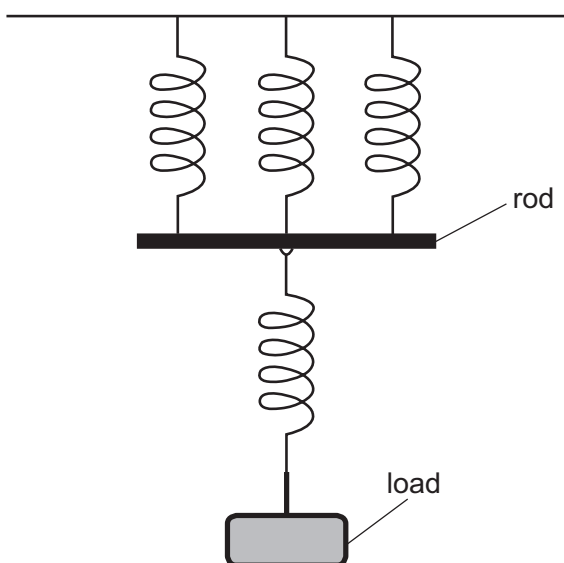

The spring constant of each spring is k and all four springs obey Hooke's law throughout. Which of the following expressions gives the elastic potential energy stored in the system? (gravitational field strength = g)

- A $\frac{(mg)^2}{6k}$
B $\frac{(mg)^2}{2k}$
C $\frac{5(mg)^2}{9k}$
D $\frac{2(mg)^2}{3k}$
E $\frac{(mg)^2}{k}$
F $\frac{2(mg)^2}{k}$

- 11 A block of mass 3.60 kg is held stationary on a rough slope inclined at 30.0° to the horizontal. The edge X of the block is 1.50 m from the bottom of the slope.

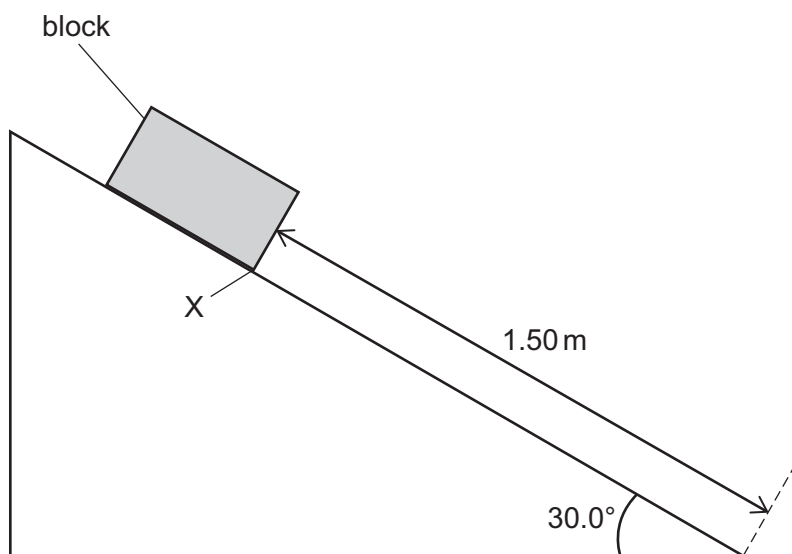

The block is released and it accelerates uniformly down the slope. When X reaches the bottom of the slope, the speed of the block is 2.00 m s^{-1} .

What is the average rate at which work is done against resistive forces?

(gravitational field strength = 10 N kg^{-1})

- A 4.8 W
- B 13.2 W
- C 15.6 W
- D 18.0 W
- E 26.4 W

- 12 A circuit contains a battery with internal resistance and two resistors, connected as shown in the diagram.

The emf of the battery is 6.00 V. The pd across the 20.0 Ω resistor is 4.80 V.

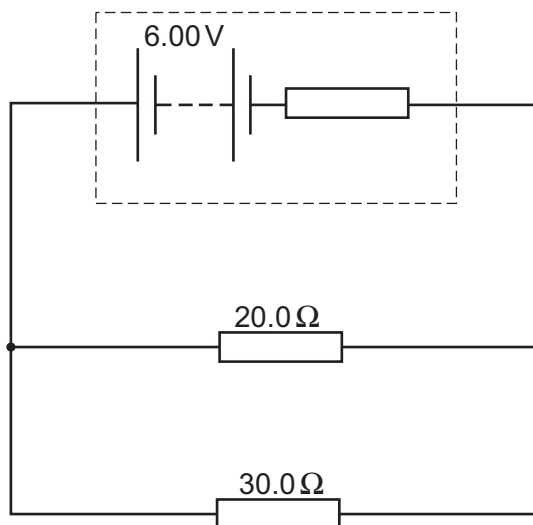

What is the internal resistance of the battery?

- A 0.0800 Ω
- B 0.333 Ω
- C 0.480 Ω
- D 3.00 Ω
- E 12.0 Ω
- F 12.5 Ω
- G 15.0 Ω

- 13 A stick at position X dips into water every 0.80 s, creating a circular wave which travels at a constant speed.

The diagrams show the wave crests at a time t and 1.0 s later. One of the wave crests, labelled Q, appears in both diagrams.

In each diagram, the distance from X to a wave crest is labelled.

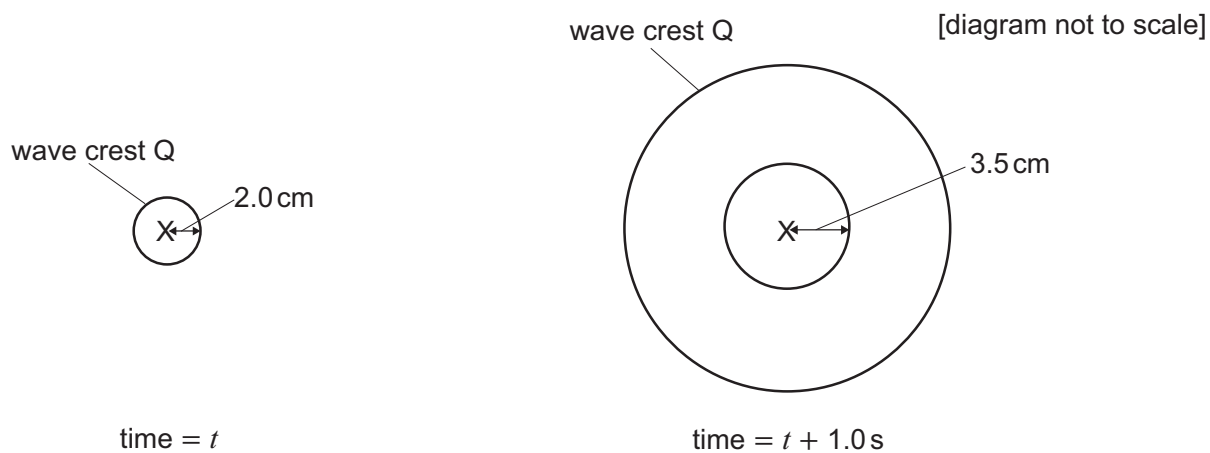

What is the wavelength of the wave?

- A 1.2 cm
- B 1.5 cm
- C 2.0 cm
- D 3.5 cm
- E 4.4 cm
- F 6.0 cm
- G 7.5 cm
- H 14 cm

14 A block P has a smaller block Q resting on its top surface.

Q is connected to a hanging block, R, by a light, inextensible string. The string passes over a smooth pulley which is connected to block P, as shown in the diagram.

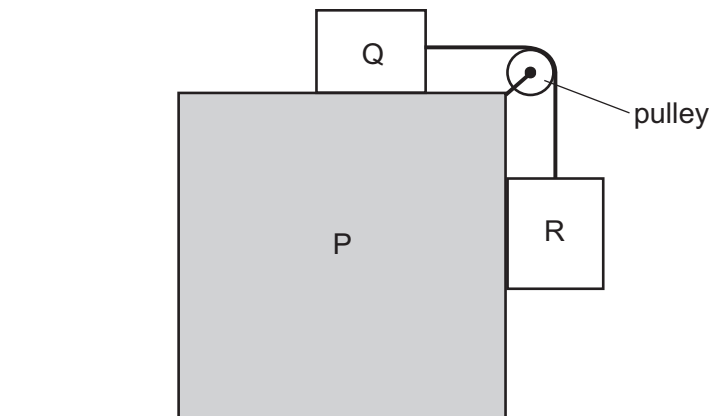

The masses of blocks P, Q and R are m_P , m_Q and m_R respectively.

The surfaces of the three blocks are smooth.

P is accelerated horizontally to the right by an external force. While this is happening, Q and R do not move relative to P.

What is the acceleration of P?

(gravitational field strength = g)

A $\frac{m_Q g}{m_R}$

B $\frac{m_R g}{m_Q}$

C $\frac{m_R g}{m_R + m_Q}$

D $\frac{m_Q g}{(m_P + m_Q + m_R)}$

E $\frac{m_R g}{(m_P + m_Q + m_R)}$

F $\frac{(m_Q + m_R)g}{(m_P + m_Q + m_R)}$

- 15 A solid cube with a total surface area of 96 cm^2 is suspended from a spring of spring constant $2.0 \times 10^4 \text{ Nm}^{-1}$ and causes the spring to extend by $1.6 \times 10^{-4} \text{ m}$.

The cube is removed from the spring and placed on a horizontal surface where it rests with one face on the surface.

What is the pressure exerted by the cube on the surface and what is the density of the material from which the cube is made?

(gravitational field strength = 10 N kg^{-1})

	<i>pressure / Nm^{-2}</i>	<i>density / kg m^{-3}</i>
A	2.0×10^1	5.0×10^{-2}
B	2.0×10^1	5.0×10^4
C	3.3×10^2	5.0×10^{-2}
D	3.3×10^2	5.0×10^3
E	3.3×10^2	5.0×10^4
F	2.0×10^3	5.0×10^{-2}
G	2.0×10^3	5.0×10^3
H	2.0×10^3	5.0×10^4

- 16 A power cable consists of a cylindrical copper (Cu) wire surrounded by six cylindrical aluminium (Al) wires. All the wires are of the same cross-sectional area as shown:

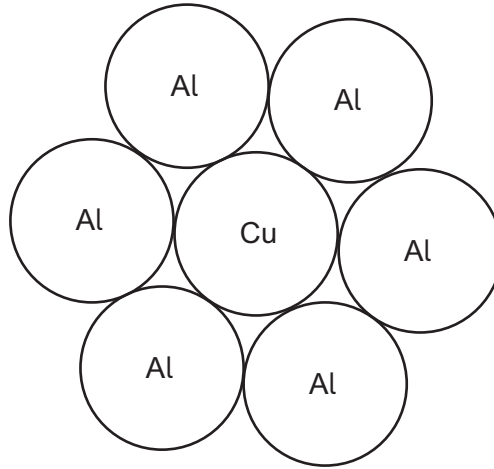

The table gives the densities and resistivities of aluminium and copper.

<i>material</i>	<i>density</i>	<i>resistivity</i>
aluminium	d	3ρ
copper	$3d$	2ρ

The cable has mass M and length L .

Which expression gives the resistance between the two ends of the cable?

- A $\frac{18\rho dL^2}{5M}$
- B $\frac{21\rho dL^2}{M}$
- C $\frac{81\rho dL^2}{5M}$
- D $\frac{180\rho dL^2}{M}$
- E $\frac{12\rho dL^2}{5M}$
- F $\frac{28\rho dL^2}{3M}$
- G $\frac{36\rho dL^2}{5M}$
- H $\frac{80\rho dL^2}{M}$

- 17 Oil of density 800 kg m^{-3} is pumped through a pipe of circular cross-sectional area 0.60 m^2 at a speed of 5.0 ms^{-1} . Between X and Y, the cross-sectional area of the pipe decreases to 0.25 m^2 .

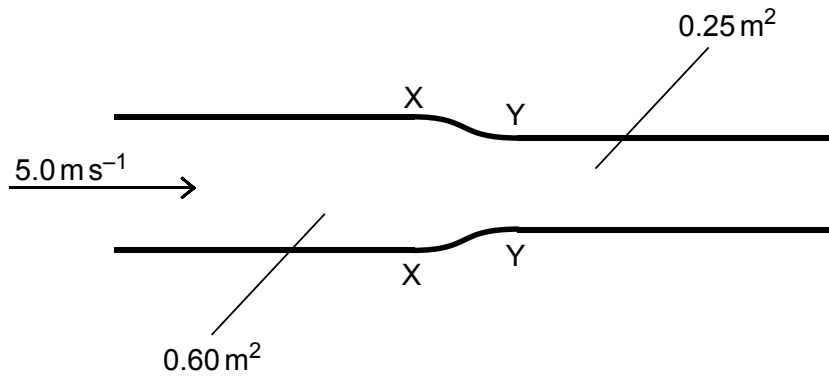

What is the resultant force exerted on the oil as it passes from X to Y?

- A 0 N
- B 7000 N
- C 12000 N
- D 16800 N
- E 19000 N
- F 24000 N
- G 40800 N
- H 143000 N

- 18 A small steel ball of mass m is released from the top of a semi-circular ramp of radius r as shown in the diagram:

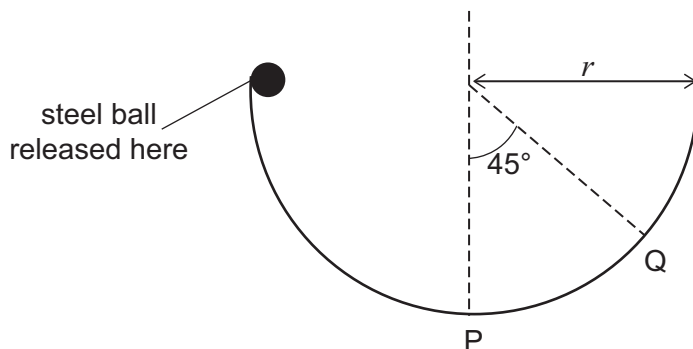

[diagram not to scale]

After being released, the ball moves around the semi-circle to the lowest point at position P and then rises to a maximum height on the other side at position Q before falling down again.

Assume that the friction force acting on the ball has a constant magnitude whilst the ball is moving.

What is the kinetic energy of the ball as it first passes position P?

(gravitational field strength = g)

- A $mgr(\sqrt{2} - 1)$
- B $mgr\left(1 - \frac{\sqrt{2}}{3}\right)$
- C $mgr\left(1 - \frac{\sqrt{2}}{4}\right)$
- D $\frac{2mgr}{3}$
- E $\frac{3mgr}{4}$
- F $mgr\left(\frac{1+\sqrt{2}}{3}\right)$
- G mgr
- H $mgr\left(2 - \frac{\sqrt{2}}{2}\right)$

END OF TEST

This page is intentionally left blank for your working or notes.

This page is intentionally left blank for your working or notes.

This page is intentionally left blank for your working or notes.

J



Engineering Admissions Assessment – Section 2 2018

D564/12

Candidate number

J

Centre number

Date of birth (DD MM YYYY)

First name(s)

Surname / Family name

Fill in the appropriate circle for your chosen answer e.g.

A B C D E
○ ● ○ ○ ○

Use a soft pencil. If you make a mistake, erase thoroughly and try again.

* 1 6 5 1 7 6 2 9 7 5 *

1 A B C D E
○ ○ ○ ○ ○

2 A B C D E F
○ ○ ○ ○ ○ ○

3 A B C D E F
○ ○ ○ ○ ○ ○

4 A B C D E F G
○ ○ ○ ○ ○ ○ ○

5 A B C D E F
○ ○ ○ ○ ○ ○

6 A B C D E F
○ ○ ○ ○ ○ ○

7 A B C D E F G H
○ ○ ○ ○ ○ ○ ○ ○

8 A B C D E F G H
○ ○ ○ ○ ○ ○ ○ ○

9 A B C D E F G
○ ○ ○ ○ ○ ○ ○

10 A B C D E F
○ ○ ○ ○ ○ ○ ○

11 A B C D E
○ ○ ○ ○ ○

12 A B C D E F G
○ ○ ○ ○ ○ ○ ○

13 A B C D E F G H
○ ○ ○ ○ ○ ○ ○ ○

14 A B C D E F
○ ○ ○ ○ ○ ○

15 A B C D E F G H
○ ○ ○ ○ ○ ○ ○ ○

16 A B C D E F G H
○ ○ ○ ○ ○ ○ ○ ○

17 A B C D E F G H
○ ○ ○ ○ ○ ○ ○ ○

18 A B C D E F G H
○ ○ ○ ○ ○ ○ ○ ○

