

# University of Cambridge Local Examinations Syndicate

## Biomedical Admissions Test

Wednesday                      3 November 2004                      Morning                      30 minutes

### SECTION 2                      Scientific Knowledge and Applications

#### Instructions to Candidates

**Please read this page carefully, but do not open the question paper until you are told that you may do so.**

A separate answer sheet is provided for this section. Please check you have one. You also require a soft pencil and an eraser.

Please first write your name, date of birth, Biomedical Admissions Test candidate number and centre number in the spaces provided on the answer sheet. Please write very clearly.

Please also write your BMAT candidate number in the spaces below.

#### BMAT Candidate Number

--	--	--	--	--

Speed as well as accuracy is important in this section. **Work quickly, or you may not finish the paper.** There are no penalties for incorrect responses, only points for correct answers, so you should attempt all 27 questions. Unless otherwise stated, all questions are worth one mark.

Answer on the sheet provided. Many questions ask you to show your choice between options by shading a circle (or circles, if specified in the question). If questions ask you to write in words or numbers, be sure to write clearly in the spaces provided. If you make a mistake, erase thoroughly and try again.

Any rough work should be done on this question paper.

Calculators are NOT permitted.

**Please wait to be told you may begin before turning this page.**

*This paper consists of 12 printed pages and 4 blank pages.*

**The questions in this paper that are marked with an asterisk (\* Qs: 4, 5, 10, 11, 13, 21, 23, 24, 26) assume knowledge that is not currently on the BMAT specification.**

**BLANK PAGE**

- 1 The diagram shows a view from the front of a section through the heart and associated blood vessels.

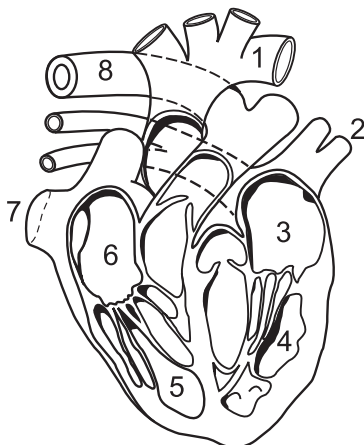

Which sequence of numbers shows the course of blood flow from the point of entry to the heart from the lungs, to its eventual exit from the heart to supply the lungs?

- A  $2 \rightarrow 3 \rightarrow 4 \rightarrow 8 \rightarrow 1 \rightarrow 5 \rightarrow 6 \rightarrow 7$   
 B  $2 \rightarrow 3 \rightarrow 4 \rightarrow 1 \rightarrow 7 \rightarrow 6 \rightarrow 5 \rightarrow 8$   
 C  $7 \rightarrow 6 \rightarrow 5 \rightarrow 8 \rightarrow 2 \rightarrow 3 \rightarrow 4 \rightarrow 1$   
 D  $7 \rightarrow 6 \rightarrow 5 \rightarrow 1 \rightarrow 8 \rightarrow 4 \rightarrow 3 \rightarrow 2$   
 E  $8 \rightarrow 5 \rightarrow 6 \rightarrow 7 \rightarrow 2 \rightarrow 3 \rightarrow 4 \rightarrow 1$   
 F  $8 \rightarrow 5 \rightarrow 6 \rightarrow 7 \rightarrow 1 \rightarrow 4 \rightarrow 3 \rightarrow 2$
- 2 The right-angled triangle shown has horizontal and vertical sides measuring  $(4 + \sqrt{2})$  cm and  $(2 - \sqrt{2})$  cm respectively.

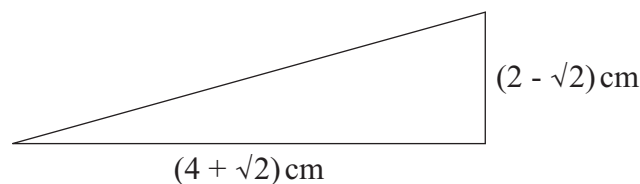

(not to scale)

Calculate the area of the triangle.

- A  $(5 + 3\sqrt{2}) \text{ cm}^2$   
 B  $(3 - \sqrt{2}) \text{ cm}^2$   
 C  $(3 + 3\sqrt{2}) \text{ cm}^2$   
 D  $(5 - \sqrt{2}) \text{ cm}^2$

- 3 The equation summarises the reaction of copper and dilute nitric acid.

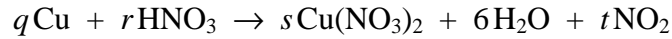

What values of  $q$ ,  $r$ ,  $s$  and  $t$  are needed to balance the equation?

- \* 4 The diagram shows a simplified version of the brake pedal of a car.

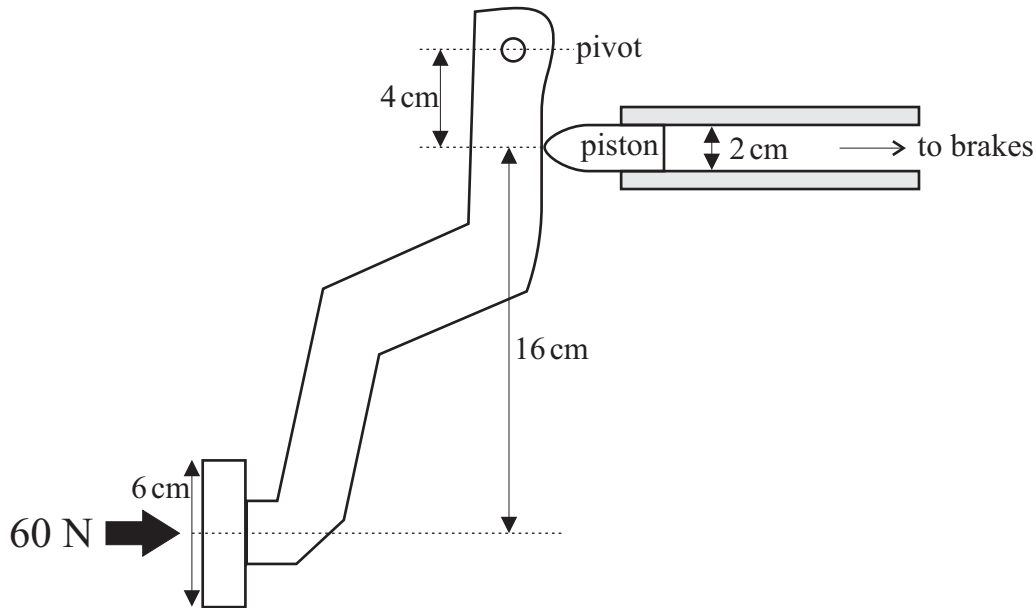

A driver applies a force of 60 N to the pedal. What force is applied to the piston?

- A 15 N
- B 20 N
- C 180 N
- D 240 N
- E 300 N
- F 540 N

- \* 5 During the electrolysis of hydrochloric acid, positively charged hydrogen ions move towards the cathode at a rate of  $10^{18}$  ions per second. Negatively charged chloride ions move towards the anode at the same rate. Both hydrogen and chloride ions carry charges of magnitude  $1.6 \times 10^{-19}$  C.

What is the resulting current flow between the electrodes?

- 6 The diagram shows a section through the thorax.

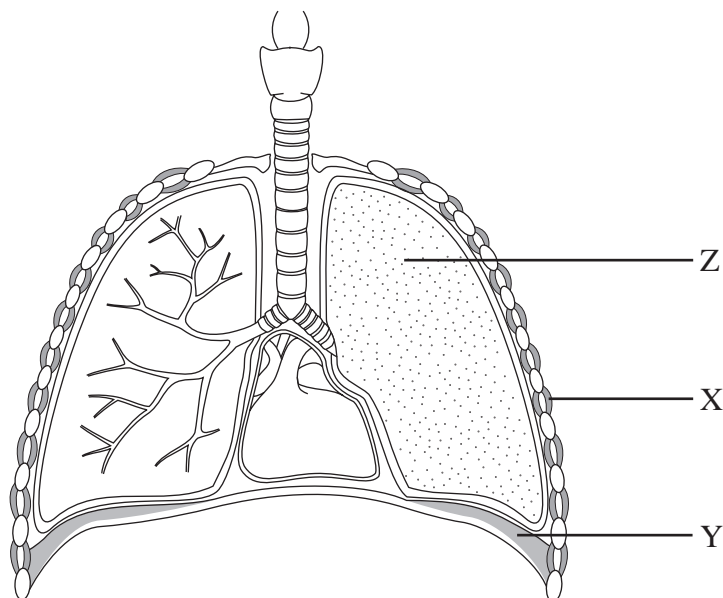

When breathing out (expiring), what happens to the muscles at X and Y and the pressure at Z?

	muscle X	muscle Y	pressure Z
<b>A</b>	contracts	contracts	increases
<b>B</b>	contracts	relaxes	increases
<b>C</b>	relaxes	contracts	decreases
<b>D</b>	relaxes	relaxes	decreases
<b>E</b>	relaxes	relaxes	increases

- 7 The table shows some properties of five substances A - E.

substance	melting point °C	boiling point °C	electrical conductivity	
			when solid	when molten
<b>A</b>	800	1470	none	good
<b>B</b>	98	880	good	good
<b>C</b>	-20	58	none	none
<b>D</b>	114	444	none	none
<b>E</b>	1700	2200	none	none

From the substances in the table, select the substances that could be:

- i) an inorganic substance with a giant molecular structure;
- ii) a metal;
- iii) an ionic compound;
- iv) a liquid at room temperature and atmospheric pressure.

- 8 An oxide of tungsten contains 79.31% by mass of tungsten.

What is the formula of this oxide? (relative atomic masses: O = 16; W = 184)

- A WO
- B  $W_2O_3$
- C  $WO_2$
- D  $W_3O_4$
- E  $WO_3$

- 9 A ball is thrown vertically upwards and leaves the thrower's hand with a speed of 12 m/s. Calculate the height to which it rises. You may assume that all of the initial kinetic energy of the ball has been converted into gravitational potential energy when the ball reaches its highest point. (Take the value of  $g$  to be 10 N/kg.)

- \* 10 The diagram shows two sets of parallel lines. Angles  $\theta$ ,  $\alpha$ ,  $\beta$  and  $\gamma$  are as marked.

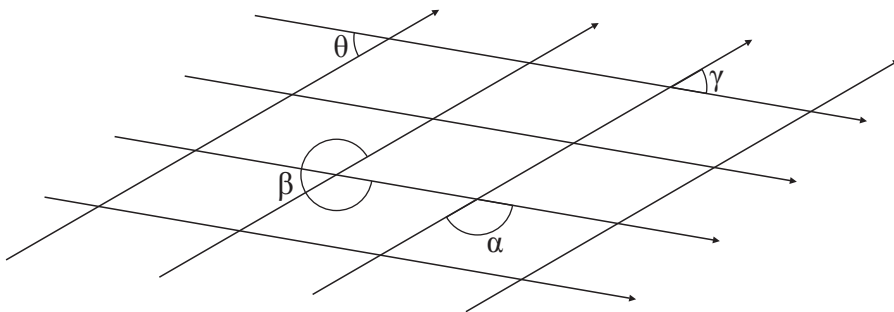

Which of the following statements are true? (shade **all** that apply)

- A  $\cos \alpha = -\cos \theta$
- B  $\sin \beta = -\sin \theta$
- C  $\tan \gamma = -\tan \theta$
- D  $\sin (\theta + \alpha) = 1$

- \* 11 One of the steps in the breakdown of glucose is the conversion of pyruvic acid,  $\text{CH}_3\text{COCO}_2\text{H}$ , into lactic acid,  $\text{CH}_3\text{CH}(\text{OH})\text{CO}_2\text{H}$ .

This is an example of:

- A oxidation
- B reduction
- C hydration
- D acidification

- 12 The diagram shows a family tree.

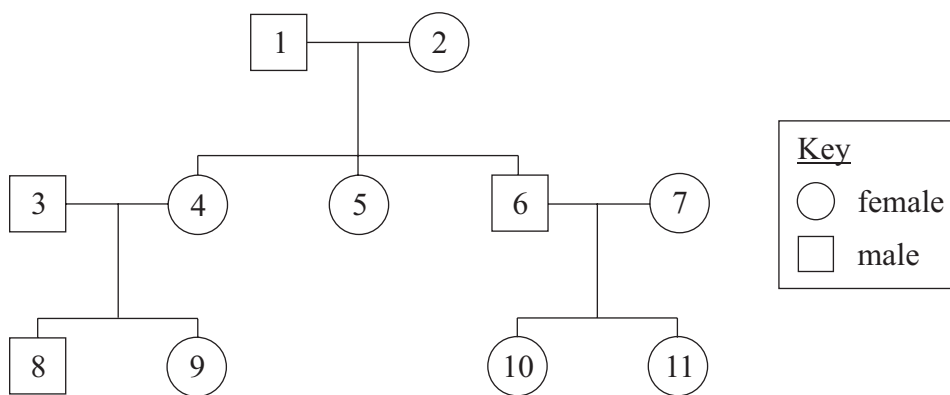

The grandfather, individual 1, carries a recessive allele on his X chromosome. Which other individuals could have inherited this allele?

- A 3,4,5,6
- B 3,4,5,7
- C 4,5,6,8
- D 4,5,8,9
- E 5,8,9,10
- F 6,8,9,11

- \* 13 Solve the inequality

$$x^2 \geq 8 - 2x$$

- A  $x \geq 4$
- B  $x \leq 2$  and  $x \geq -4$
- C  $x \geq -2$  and  $x \leq 4$
- D  $x \geq 2$  or  $x \leq -4$

- 14 Plugs of cotton wool containing concentrated aqueous ammonia and concentrated hydrochloric acid are placed at opposite ends of a tube, at room temperature. A white ring of solid ammonium chloride forms nearer the hydrochloric acid.



Which of the following can be deduced from this experiment?

- A The ammonia molecule has more atoms than the hydrogen chloride molecule.  
 B The boiling point of ammonia is less than that of hydrogen chloride.  
 C The concentration of the aqueous ammonia is less than that of the acid.  
 D The mass of an ammonia molecule is less than that of a hydrogen chloride molecule.  
 E The reactivity of ammonia is less than that of hydrogen chloride.
- 15 In these circuits the cells are identical and their internal resistances can be ignored.

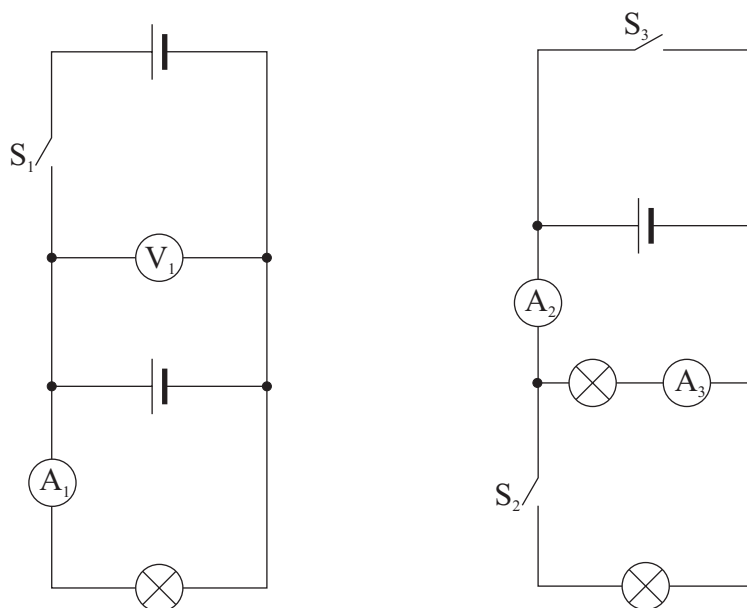

Indicate whether each of the statements below is **true** or **false** for the circuits shown.

- i) When switch  $S_1$  is closed, the reading on voltmeter  $V_1$  will increase.  
 ii) When switch  $S_1$  is closed, the reading on ammeter  $A_1$  will increase.  
 iii) When switch  $S_2$  is closed, the reading on ammeter  $A_2$  will increase.  
 iv) When switch  $S_2$  is closed, the reading on ammeter  $A_3$  will decrease.  
 v) When switch  $S_3$  is closed, the reading on ammeter  $A_2$  will increase.



- 16** In 2001 a quarter of the population of Wales reported having a limiting long-term illness or disability which restricted their daily activities.

What is the probability that out of a random group of three people who live in Wales, exactly one of them will have reported such an illness or disability?

- A**  $\frac{9}{64}$   
**B**  $\frac{27}{64}$   
**C**  $\frac{37}{64}$   
**D**  $\frac{3}{4}$

- 17** A parachutist of total mass 90 kg (including the parachute) is falling at a terminal velocity of 6 m/s. Take the force due to gravity on a mass of 1 kg to be 10 N. What is the magnitude of the air resistance force acting on her?

- A** zero  
**B** 150 N  
**C** 540 N  
**D** 900 N  
**E** 5400 N

- 18** The general formula for the alkane series of hydrocarbons is  $C_nH_{2n+2}$

The primary amine series has the same saturated structure as the alkanes, but also contains an  $-NH_2$  group.

What is the general formula for the primary amine series?

- A**  $C_nH_{2n}N$   
**B**  $C_nH_{2n+1}N$   
**C**  $C_nH_{2n+2}N$   
**D**  $C_nH_{2n+3}N$

- 19 The diagram shows three sperm and three ova containing sex chromosomes X and Y (not drawn to scale).

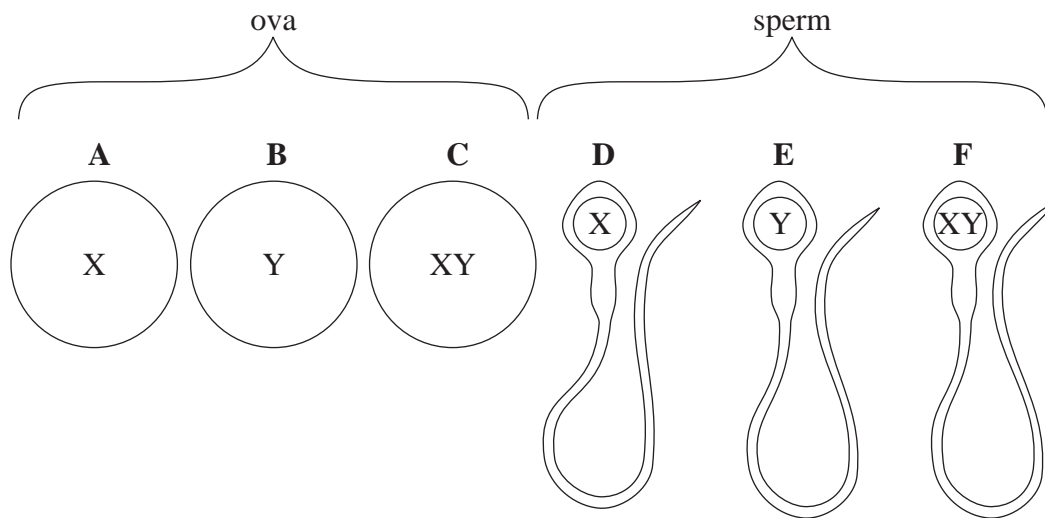

Indicate the letters (A to F) of **all** the sex cells which are normal.

- 20 Which **one** of the following is **not** a measure of electrical power?  
( $V$  = potential difference,  $I$  = current,  $Q$  = charge,  $t$  = time,  $R$  = resistance)

A  $\frac{QV}{t}$

B  $I^2R$

C  $\frac{Q^2R}{t}$

D  $VI$

E  $\frac{V^2}{R}$

- \* 21 Which blood vessel will have capillaries at both ends?

- A Anterior vena cava  
 B Aorta  
 C Hepatic artery  
 D Hepatic portal vein  
 E Renal vein

- 22 Nuclide P decays by emission of ionising radiation to produce nuclide Q. This new nuclide then decays by further emission into nuclide R. The process is shown below, with the appropriate mass numbers (nucleon numbers) and atomic numbers (proton numbers).

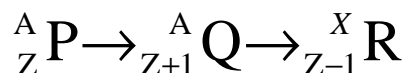

Which line in the table shows the type of particle emitted at each stage, and the value of X?

	first decay	second decay	value X
A	alpha	alpha	A
B	alpha	alpha	A - 2
C	alpha	beta	A - 4
D	beta	beta	A
E	beta	alpha	A - 2
F	beta	alpha	A - 4

- \* 23 In water, the  $\text{Fe}^{2+}$  ion bonds with water to form  $\text{Fe}(\text{H}_2\text{O})_6^{2+}$ . In haemoglobin in the blood, five of the water molecules have been displaced. In the presence of air, the last water molecule is displaced by oxygen to give oxyhaemoglobin. In the presence of carbon monoxide, the oxygen is displaced to give carboxyhaemoglobin.

Which of the following shows the correct order of the strength of the bonding to the  $\text{Fe}^{2+}$  ion (weakest first)?

- weakest**  $\longrightarrow$  **strongest**
- A carbon monoxide, water, oxygen  
 B carbon monoxide, oxygen, water  
 C oxygen, water, carbon monoxide  
 D oxygen, carbon monoxide, water  
 E water, oxygen, carbon monoxide  
 F water, carbon monoxide, oxygen

- \* 24 The diagram shows the leg muscles of an athlete leaving the starting blocks for a race.

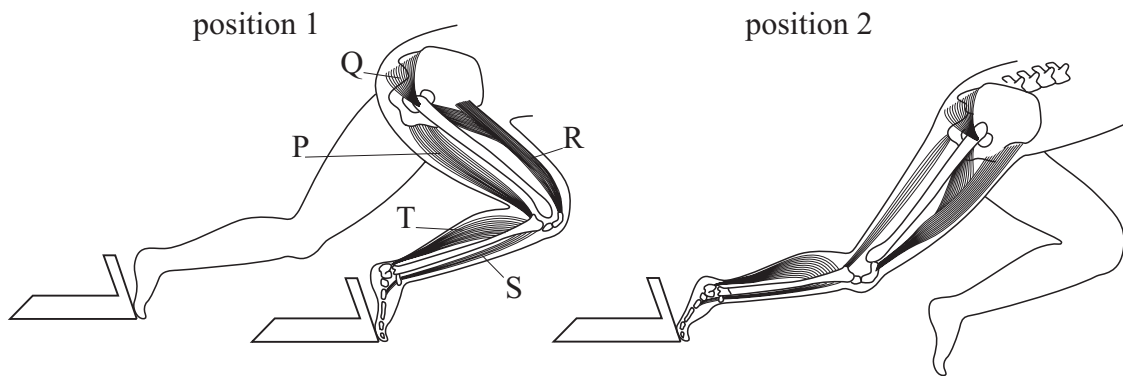

Which muscles contract and which relax to bring about the change from position 1 to position 2?

	muscles that contract	muscles that relax
A	P, Q, R	S, T
B	T, P	Q, R, S
C	Q, R, T	P, S
D	R, S	P, Q, T
E	Q, R, S	P, T

- 25 For a rigid body performing small oscillations about a fixed horizontal axis, the period of oscillations is given by

$$T = 2\pi \sqrt{\frac{(k^2 + h^2)}{gh}}$$

where  $h$  is the distance of the centre of mass from the axis,  $g$  is the acceleration due to gravity, and  $k$  is the radius of gyration of the body about a parallel axis through the centre of mass.

Rearrange the formula to make  $k$  the subject.

A  $k = \left(\frac{T}{2\pi}\right)^2 gh - h$

B  $k = \sqrt{\left(\frac{T^2 g^2 h^2}{4\pi^2} - h^2\right)}$

C  $k = \sqrt{(T - 2\pi)^2 gh - h^2}$

D  $k = \sqrt{\left(\frac{T^2 gh}{4\pi^2} - h^2\right)}$

- \* **26** The list below describes some events that occur during nuclear division.

Indicate, by shading the appropriate circles on the answer sheet, which events occur during mitosis and which occur during meiosis.

- i** daughter nuclei are identical to parent nucleus
- ii** all chromosomes are replicated
- iii** leads to the formation of gametes
- iv** two haploid nuclei are formed
- v** genetic material appears as distinct chromosomes

- 27** The sum of the roots of a quadratic equation is 7, the product of the roots is 9. What is the equation?

- A**  $x^2 + 7x + 9 = 0$
- B**  $x^2 + 7x - 9 = 0$
- C**  $x^2 - 7x + 9 = 0$
- D**  $x^2 - 7x - 9 = 0$

**END OF SECTION 2**

**BLANK PAGE**

**BLANK PAGE**

**BLANK PAGE**