

GCSE Physics B (Twenty First Century Science)
J259/02 Depth in physics (Foundation Tier)

Question Set 16

1 Nina is investigating electrical circuits in the laboratory.

(a) Nina is looking for a filament lamp for her torch.

Fig. 1.1 shows a filament lamp that may be suitable.

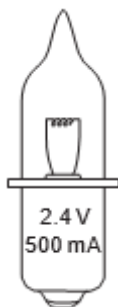
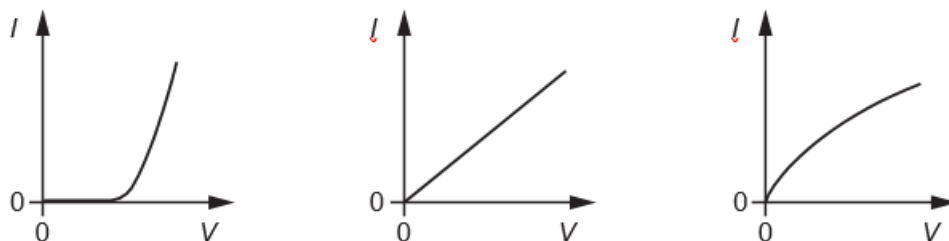

Fig. 1.1

(i) Which current against voltage graph (I - V characteristic) for a filament lamp is correct?

Put a ring around the correct answer.



[1]

(ii) Calculate the amount of charge flowing through the filament lamp when it is used for 60 s.

Use the equation: charge = current \times time

Charge = C [3]

(iii) The base of the filament lamp has '2.4 V, 500 mA' stamped on it.

Calculate the power of the filament lamp at 2.4 V.

Power = W [3]

- (b) Nina connects up the following circuit using two identical filament lamps.

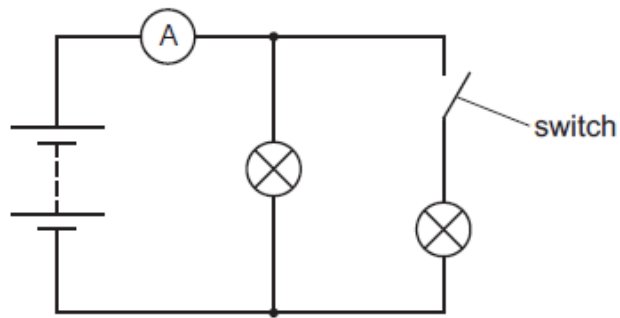

Fig. 1.2

The switch is currently open.

Explain what happens to the ammeter reading when the switch is then **closed**. [2]

- (c) (i) What is the name of the electrical component that conducts current in **only one** direction?

Tick (✓) **one** box.

Diode

Lamp

Light-Dependent Resistor (LDR)

Thermistor

[1]

- (ii) Draw an electrical symbol for your answer to (c)(i).

[1]

Total Marks for Question Set 16: 11

OCR

Oxford Cambridge and RSA

Copyright Information

OCR is committed to seeking permission to reproduce all third-party content that it uses in its assessment materials. OCR has attempted to identify and contact all copyright holders whose work is used in this paper. To avoid the issue of disclosure of answer-related information to candidates, all copyright acknowledgements are reproduced in the OCR Copyright Acknowledgements Booklet. This is produced for each series of examinations and is freely available to download from our public website (www.ocr.org.uk) after the live examination series.

If OCR has unwittingly failed to correctly acknowledge or clear any third-party content in this assessment material, OCR will be happy to correct its mistake at the earliest possible opportunity.

For queries or further information please contact The OCR Copyright Team, The Triangle Building, Shaftesbury Road, Cambridge CB2 8EA.

OCR is part of the Cambridge Assessment Group; Cambridge Assessment is the brand name of University of Cambridge Local Examinations Syndicate (UCLES), which is itself a department of the University of Cambridge