



Additional Assessment Materials
Summer 2021

Pearson Edexcel GCSE in Physics (1PH0)
Foundation

Resource Set Topic C – Test 1: Waves, Light
and the electromagnetic spectrum

Questions

(Public release version)

Pearson: helping people progress, everywhere

Pearson aspires to be the world's leading learning company. Our aim is to help everyone progress in their lives through education. We believe in every kind of learning, for all kinds of people, wherever they are in the world. We've been involved in education for over 150 years, and by working across 70 countries, in 100 languages, we have built an international reputation for our commitment to high standards and raising achievement through innovation in education. Find out more about how we can help you and your students at: www.pearson.com/uk

General guidance to Additional Assessment Materials for use in 2021

Context

- Additional Assessment Materials are being produced for GCSE, AS and A levels (with the exception of Art and Design).
- The Additional Assessment Materials presented in this booklet are an **optional** part of the range of evidence teachers may use when deciding on a candidate's grade.
- 2021 Additional Assessment Materials have been drawn from previous examination materials, namely past papers.
- Additional Assessment Materials have come from past papers both published (those materials available publicly) and unpublished (those currently under padlock to our centres) presented in a different format to allow teachers to adapt them for use with candidate.

Purpose

- The purpose of this resource is to provide qualification-specific sets/groups of questions covering the knowledge, skills and understanding relevant to this Pearson qualification.
- This document should be used in conjunction with the mapping guidance which will map content and/or skills covered within each set of questions.
- These materials are only intended to support the summer 2021 series.

2 (a) A sound wave in air travels a distance of 220 m in a time of 0.70 s.

(i) State the equation linking speed, distance and time.

(1)

$$\text{Speed} = \frac{\text{distance}}{\text{time}}$$

(ii) Calculate the speed of the sound wave in air.

(2)

$$\text{Speed} = \frac{220}{0.7} = 314.2 \approx 310$$

wave speed = 310 m/s

(b) Figure 2 shows water waves spreading out from a source.

A student measures the wavelength of the waves.

He uses a ruler to measure the distance from one crest to the next crest.

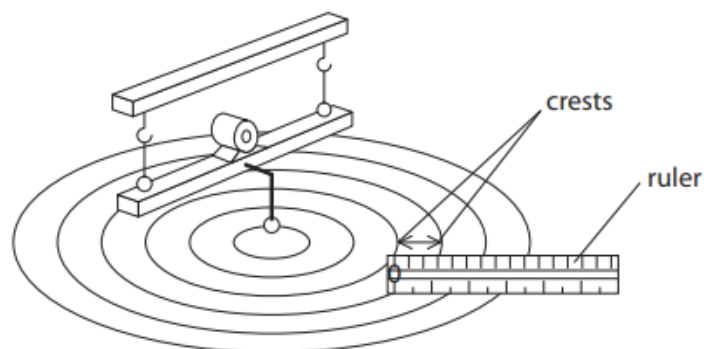

Figure 2

Explain how to improve the student's method for measuring the wavelength.

(2)

Place a camera above the ruler and capture photos to obtain the reading with high accuracy. Also take the length across two or more wavelengths and divide the reading by the number of wavelengths to reduce the error

(c) Sound waves are longitudinal waves.

Water waves are transverse waves.

Describe the difference between longitudinal waves and transverse waves.

(3)

The particles in longitudinal wave oscillate parallel to the direction of the wave movement compared to transverse where the oscillation is perpendicular to the direction of motion.

3 (a) Figure 3 shows a ray of light going from air to glass.

Fill in the labels in Figure 3 using words from the box.

critical	incident	normal	reflected	refracted
----------	----------	--------	-----------	-----------

(3)

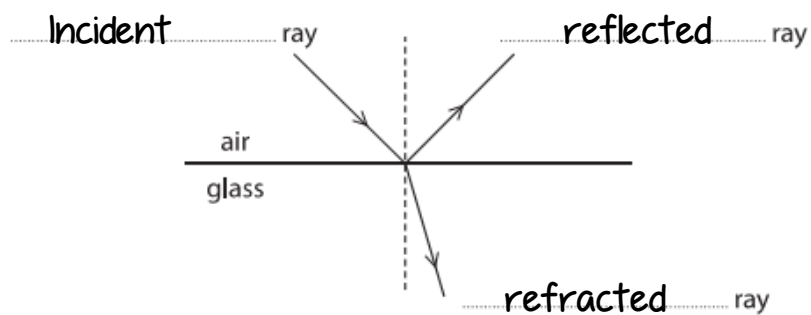

Figure 3

(c) The speed of sound in air is 300 m/s.

The speed of sound in water is 1500 m/s.

Calculate the ratio of the speed of sound in air to the speed of sound in water.

(2)

ratio of speed of sound in air to the speed of sound in water =

- 7 (a) Equal volumes of hot water are added to two cans.
The cans are identical apart from their surfaces.
One can has a black surface and the other can has a silver surface.
The cans are left to cool and their temperatures are monitored.
The graph in Figure 6 shows the results.

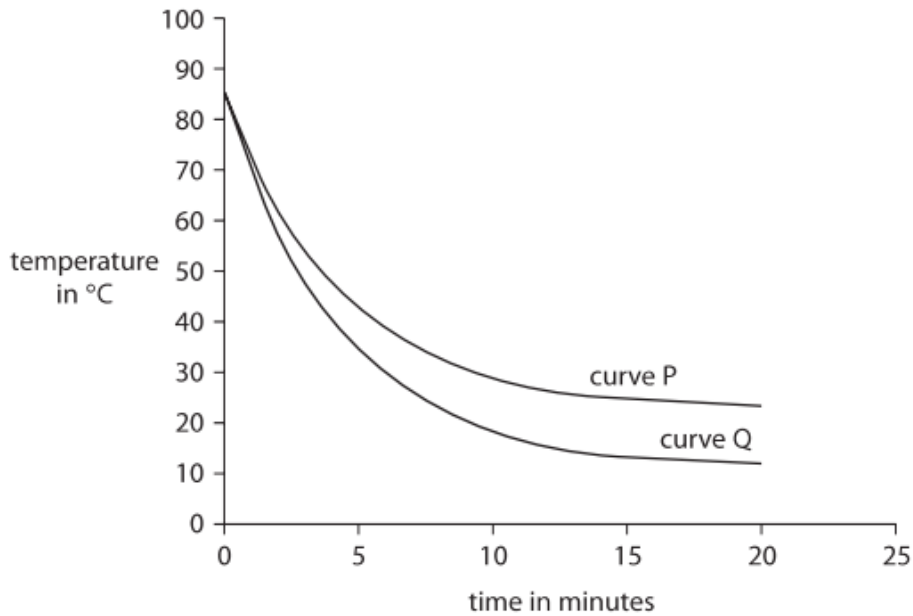

Figure 6

Explain, using evidence from the graph, which curve is for the black can and which curve is for the silver can.

(2)

The black can has the curve Q, as black is a good absorber and emitter of heat and the curve Q has a faster cooling rate. The curve Q shows a larger change in temperature in the same time, which gave evidence that the curve Q has a faster cooling rate.

*(b) Figure 7 shows some apparatus.



small infrared heating lamp



set of three cans of the same size and material but of different surfaces

Figure 7

Describe an investigation to find out how the nature of a surface affects the amount of thermal energy absorbed by the surface.

You should use the apparatus in Figure 7 and any additional items you choose. Each can in Figure 7 has a bung in the top with a hole in it.

You may use a diagram if it helps your answer.

(6)

Fix a laboratory thermometer through the hole in the bung of one of the cans. Record the initial temperature after allowing some time to reach equilibrium (constant reading in the thermometer). Keep the lamp at a known distance from the can by using a ruler and keep the lamp switched on for a known amount of time by using a stopwatch to measure the time. Measure the final temperature reading of the thermometer and solve the difference between the initial and final temperatures to find the temperature change due to the thermal energy absorbed. Repeat the experiment with the rest of the cans, keeping the distance between the lamp from the can and the duration of the lamp being switched on the same.

(ii) One star is blue and another star is red.

Explain why an astronomer expects the blue star to be hotter than the red star.

(2)

Blue has a shorter wavelength and high energy compared to red.

Since high energy translates to high temperature, it can be confirmed that the blue star is expected to be hotter.

8 (a) Which colour of visible light has the longest wavelength?

(1)

- A blue
- B green
- C red
- D yellow

(b) Some television remote controls use infrared radiation and other remote controls use radio waves.

Explain why an infrared remote control may not switch on the television from behind an armchair but a radio wave remote control always will.

(2)

Infrared needs a direct line of sight and is easily absorbed by materials (eg: the armchair).

(c) Figure 9 is a diagram of a water wave.

A cork is floating on the water.

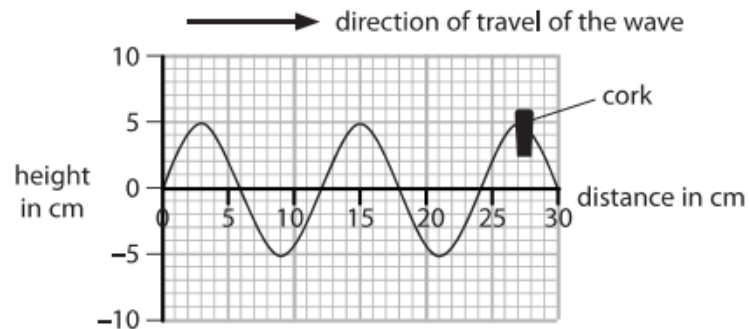

Figure 9

(i) Use the scale on the diagram to measure the wavelength of the wave.

(2)

wavelength = cm

(ii) Describe the motion of the cork.

You should include how the cork moves relative to the direction of travel of the wave.

(2)

The cork oscillates perpendicular to the direction of motion of the wave.

.....

.....

.....

(d) A different water wave has a wavelength of 0.25 m and a frequency of 1.5 Hz.

Calculate the wave speed.

(2)

wave speed = m/s

- 6 (a) Figure 11 shows a large tank of water.

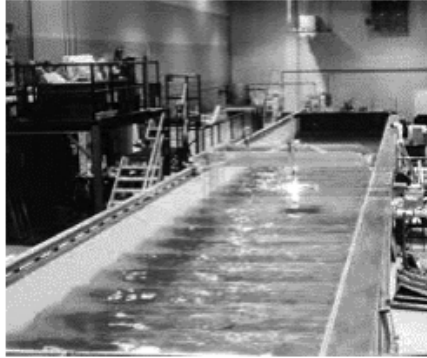

© NOAA

Figure 11

The tank of water is used to study water waves.

- (i) Water waves are transverse waves.

Give another example of a transverse wave.

(1)

Radio Waves

- (ii) Figure 12 shows a side view of part of the tank.

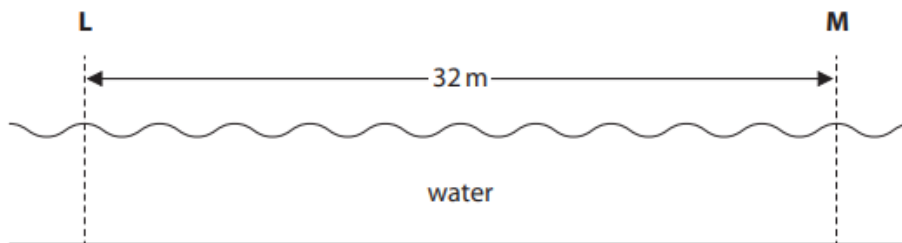

Figure 12

A water wave is moving from **L** to **M**.

Calculate the wavelength of the wave.

(2)

wavelength = m

- (iii) A technician stands at the side of the tank.
 He counts the peaks of the waves as they pass him.
 12 peaks pass the technician in a time of 15 s.
 Calculate the frequency of the wave.

(2)

frequency = Hz

- (b) Figure 13 shows part of the inside of the Earth below the surface.

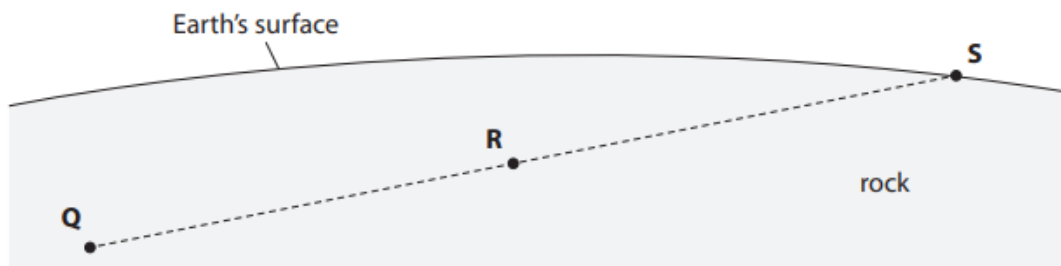

Figure 13

An earthquake starts at **Q**.

A seismic wave travels from **Q** to **S**.

The seismic wave is a longitudinal wave.

- (i) Draw arrows on Figure 13 to show how the rock at **R** moves when the seismic wave passes through **R**.

(2)

(ii) The frequency of the seismic wave is 12 Hz.

The wave speed of the seismic wave is 7 km/s.

Calculate the wavelength of the seismic wave, in metres.

Use the equation

$$\text{wavelength} = \frac{\text{wave speed}}{\text{frequency}} \quad (3)$$

wavelength = m

(c) A technician measured the frequency of the water wave in part (a) by counting how many waves passed him in 15 s.

Explain why this would **not** be a suitable method for measuring the frequency of the seismic wave in part (b)(ii).

(2)

Firstly the point R is located deep underground that is not easily accessible by a person. Furthermore, the frequency of a seismic wave is too large to count the number of waves passing through, by a human per second to obtain an accurate reading.

TOTAL FOR PAPER IS 45 MARKS