

GCSE
PHYSICS

Physics Test 4: Forces (Foundation)

Total number of marks: 36

0 1

Figure 1 shows an athlete on starting blocks waiting to start a 100 metre race.

Figure 1

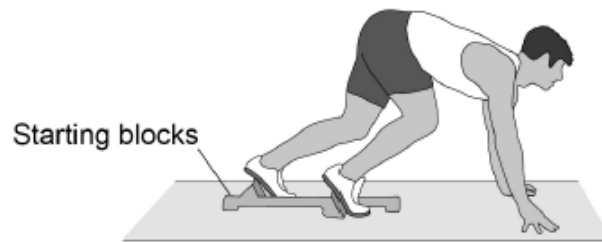

0 1 . 1

Complete the sentence.

Choose the answer from the box.

[1 mark]

equal to	greater than	less than
----------	--------------	-----------

The force from the athlete pushing backwards on the starting blocks

is _____ the force from the starting

blocks pushing forwards on the athlete.

A student investigated three different springs to compare the spring constants.

The results of the investigation are shown in **Figure 12**.

Figure 12

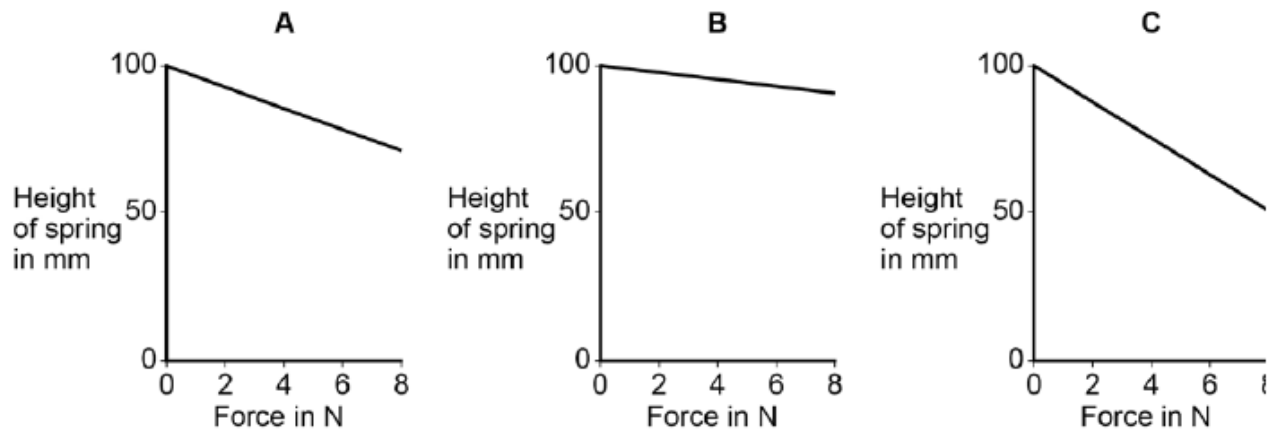

0 7 . 2 Which **one** of the springs has the smallest spring constant?

[2 marks]

Tick **one** box.

A B C

Give the reason for your answer.

Figure 13 shows a child's toy. The toy hangs from a hook in the ceiling.

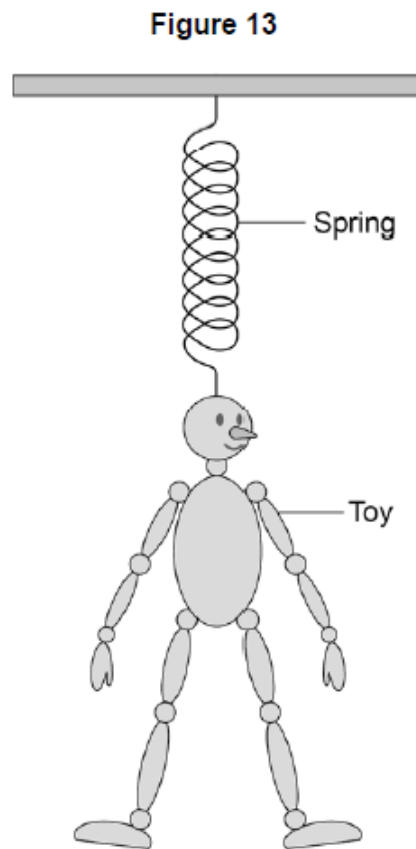

A child pulls the toy downwards and then releases it.

The toy oscillates up and down with a frequency of 1.25 Hz

0	7	.	3
---	---	---	---

 How many times each second will the toy oscillate up and down?

[1 mark]

0 6

Figure 7 shows four blocks of different materials floating on water.

The four blocks are the same volume.

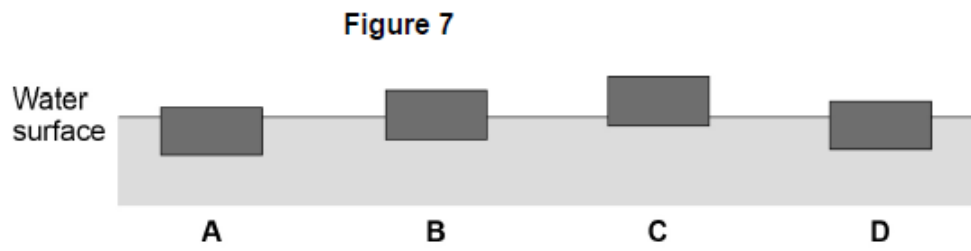

0 6 . 1

Which of the blocks has the smallest weight?

Tick **one** box.

[1 mark]

A

B

C

D

Figure 8 shows a lifebuoy next to a deep swimming pool.

Figure 8

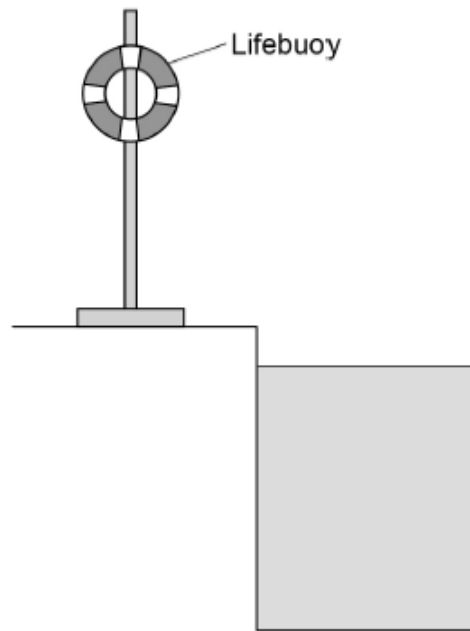

0 6 . 2

The lifebuoy has a mass of 2.5 kg.

gravitational field strength = 9.8 N/kg

Calculate the weight of the lifebuoy.

Use the equation:

$$\text{weight} = \text{mass} \times \text{gravitational field strength}$$

[2 marks]

Weight = _____ N

0 6 . 3 When thrown into the water the lifebuoy floats. The two forces acting on the lifebuoy are the weight of the lifebuoy downwards and upthrust upwards.

How big is the upthrust on the lifebuoy compared to the weight of the lifebuoy?

Tick **one** box.

[1 mark]

The upthrust is greater than the weight.

The upthrust is less than the weight.

The upthrust is the same as the weight.

0 6 . 4 Write down the equation which links acceleration, mass and resultant force.

[1 mark]

0 6 . 5 A rope is used to pull the lifebuoy to the side of the swimming pool.

A resultant force of 4.0 N acts on the lifebuoy.

The mass of the lifebuoy is 2.5 kg.

Calculate the acceleration of the lifebuoy.

[3 marks]

Acceleration = _____ m/s²

0 7 . 1 An aircraft travels at a constant velocity.

How is the velocity of the aircraft different to the speed of the aircraft?

[1 mark]

0 7 . 2 **Figure 11** shows one of the engines on the aircraft.

Figure 11

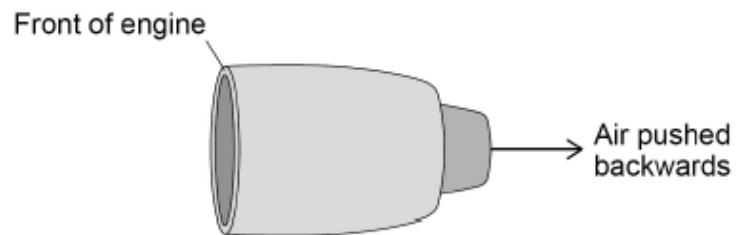

Air is taken into the front of the engine and pushed out of the back of the engine.

Explain the effect this has on the engine.

[2 marks]

07.3 Figure 12 shows a distance-time graph for the aircraft.

Figure 12

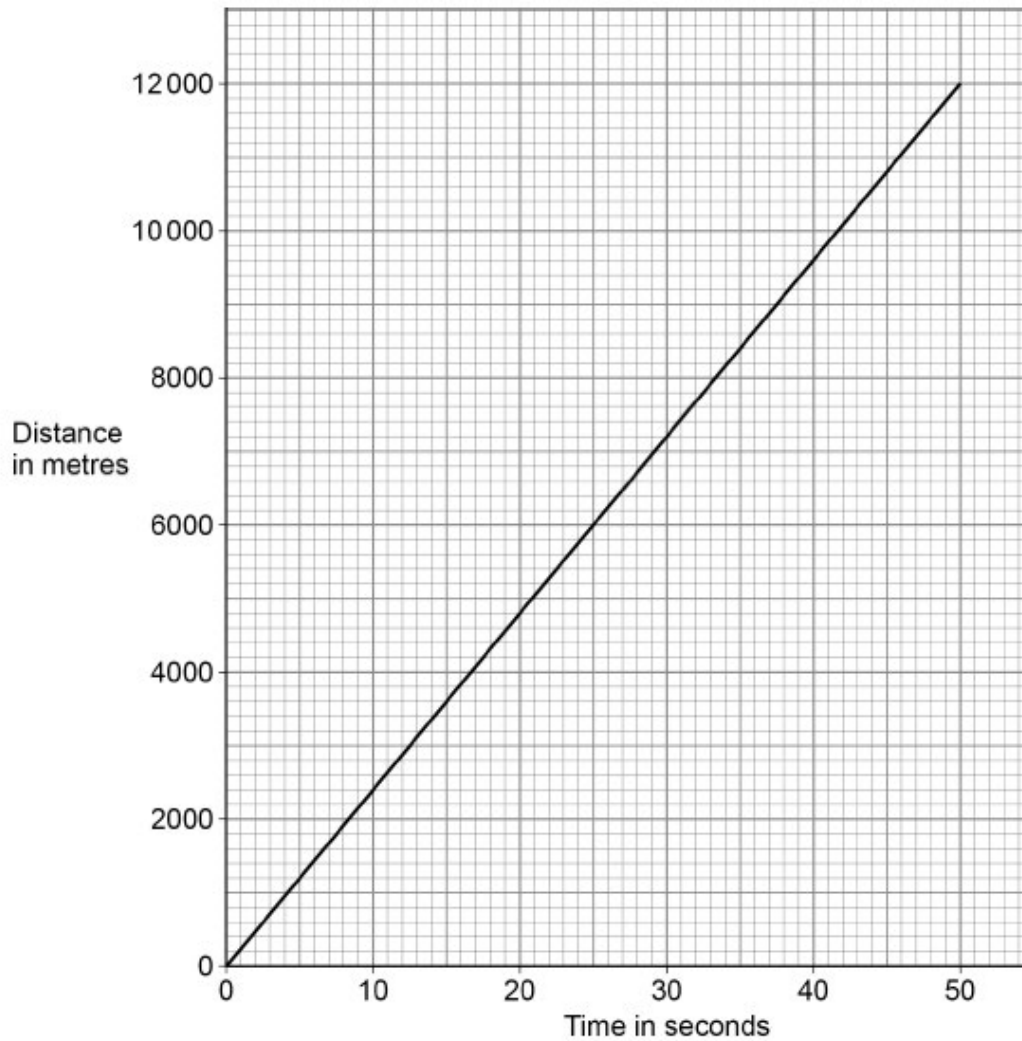

Determine the speed of the aircraft.

[3 marks]

Speed = _____ m/s

07.4 Write down the equation that links acceleration (a), change in velocity (Δv) and time taken (t).

[1 mark]

0 7 . 5 At a different stage of the flight, the aircraft was travelling at a velocity of 250 m/s.

The aircraft then decelerated at 0.14 m/s^2 .

Calculate the time taken for the aircraft to decelerate from 250 m/s to 68 m/s.

[4 marks]

Time = _____ s

0 7 . 1 Figure 17 shows four examples of a force causing an object to move.

Figure 17

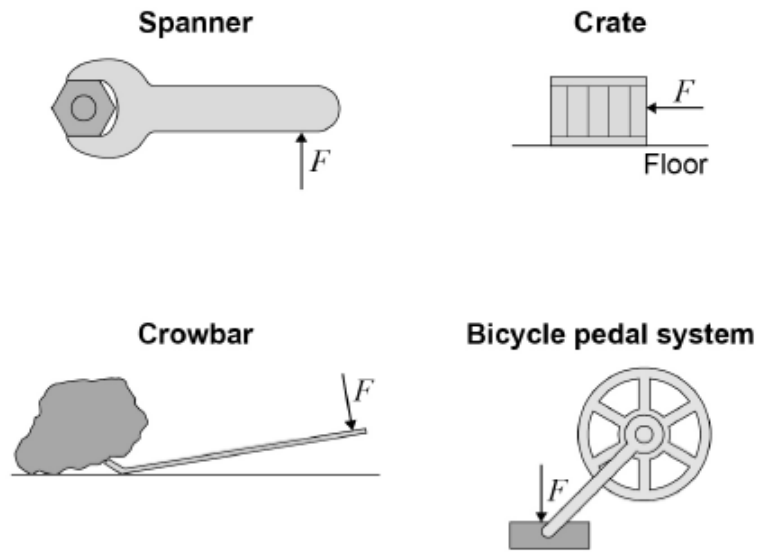

Which object is **not** likely to rotate?

[1 mark]

Tick (✓) **one** box.

- Bicycle pedal system
- Crate
- Crowbar
- Spanner

0 7

Figure 9 shows a fork-lift truck lifting a heavy crate.

Figure 9

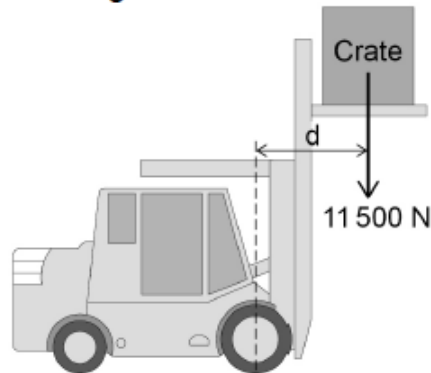

0 7 . 1

The crate weighs 11 500 N and is lifted vertically 2.60 m.

Calculate the work done to lift the crate.

Use the equation:

$$\text{work done} = \text{force} \times \text{distance}$$

[2 marks]

$$\text{Work done} = \underline{\hspace{10cm}} \text{ J}$$

The weight of the crate causes a clockwise moment of 13 800 Nm about the centre of the front wheel of the fork-lift truck.

0 7 . 2

The weight of the fork-lift truck and driver cause an anticlockwise moment.

What is the minimum size of the anticlockwise moment needed so that the fork-lift truck does **not** topple over?

[1 mark]

0 7 . 3

Write down the equation which links distance, force and moment of a force.

[1 mark]

0 7 . 4

Calculate the distance 'd' marked on Figure 9.

[3 marks]

$$\text{Distance 'd'} = \underline{\hspace{10cm}} \text{ m}$$

A student investigated the acceleration of a trolley.

Figure 13 shows how the student set up the apparatus.

Figure 13

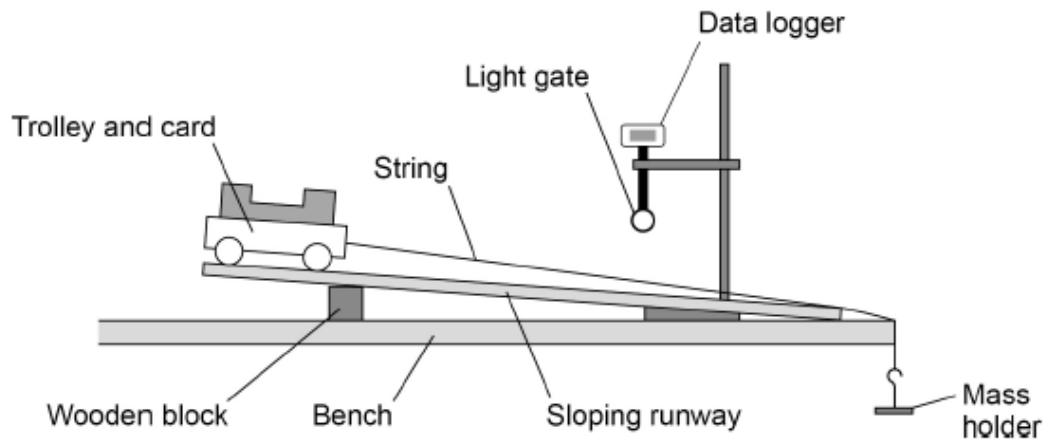

The light gate and data logger were used to determine the acceleration of the trolley.

The student increased the resultant force on the trolley and recorded the acceleration of the trolley.

Table 4 shows the results.

Table 4

Resultant force in newtons	Acceleration in m/s^2
0.05	0.08
0.10	0.18
0.15	0.25
0.20	0.32
0.25	0.41

Figure 14 is an incomplete graph of the results.

Figure 14

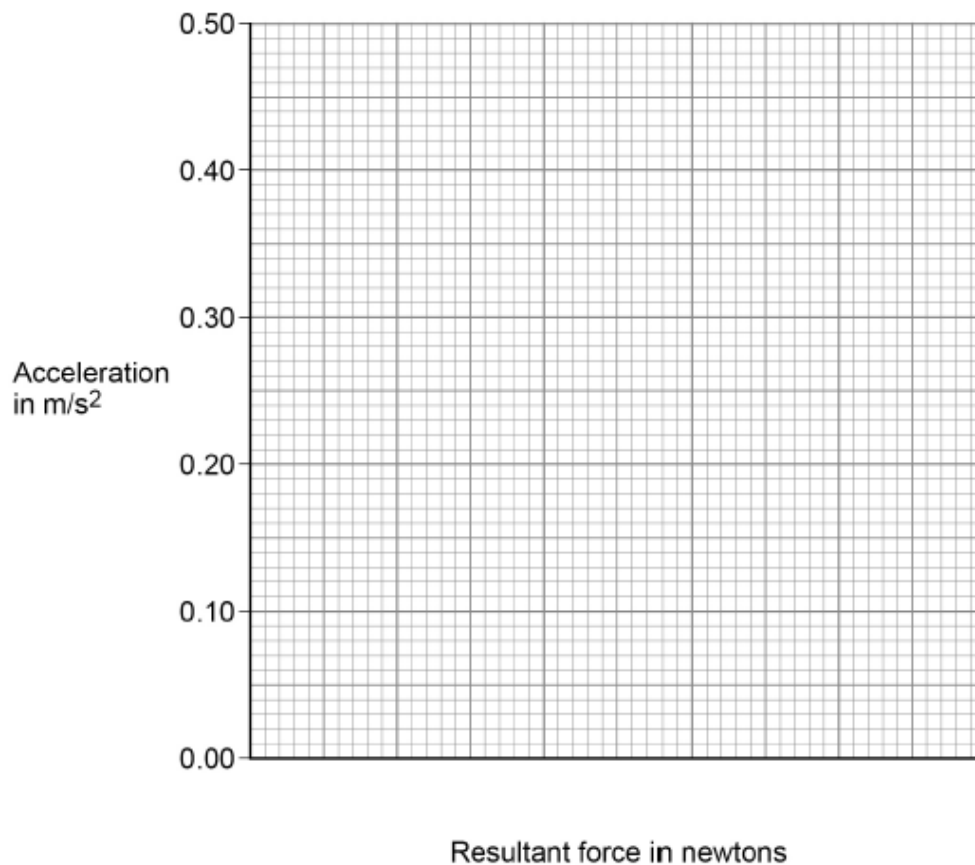

0 8 . 3 Complete **Figure 14**.

- Choose a suitable scale for the x-axis.
- Plot the results.
- Draw a line of best fit.

[4 marks]

0 8 . 4 Describe the relationship between the resultant force on the trolley and the acceleration of the trolley.

[1 mark]