

AS  
PHYSICS

7407 – Mechanics and materials / Electricity

Version 0.1

---

Total number of marks: 45

0 3 . 1 Figure 3 shows a golf ball at rest on a horizontal surface 1.3 m from a hole.

Figure 3

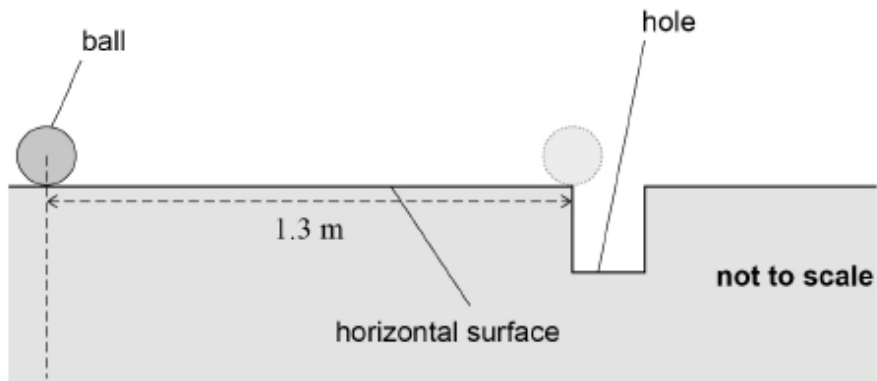

A golfer hits the ball so that it moves horizontally with an initial velocity of  $1.8 \text{ m s}^{-1}$ . The ball experiences a constant deceleration of  $1.2 \text{ m s}^{-2}$  as it travels to the hole.

Calculate the velocity of the ball when it reaches the edge of the hole.

[2 marks]

velocity = \_\_\_\_\_  $\text{m s}^{-1}$

0 3 . 2

Later, the golf ball lands in a sandpit. The golfer hits the ball, giving it an initial velocity  $u$  at  $35^\circ$  to the horizontal, as shown in **Figure 4**. The horizontal component of  $u$  is  $8.8 \text{ m s}^{-1}$ .

**Figure 4**

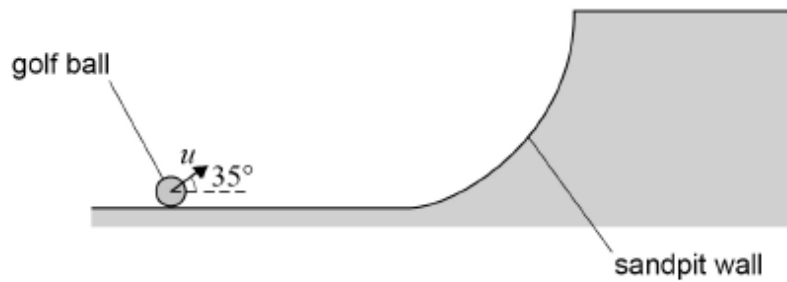

not to scale

Show that the vertical component of  $u$  is approximately  $6 \text{ m s}^{-1}$ .

[1 mark]

0 3 . 3

The ball is travelling horizontally as it reaches **X**, as shown in **Figure 5**.

**Figure 5**

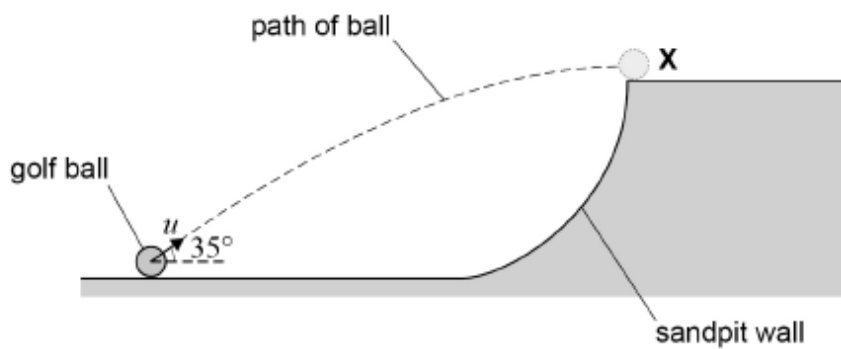

not to scale

Assume that weight is the only force acting on the ball when it is in the air.

Calculate the time for the ball to travel to **X**.

[2 marks]

time = \_\_\_\_\_ s

0 3 . 4 Calculate the vertical distance of X above the initial position of the ball.

[2 marks]

vertical distance = \_\_\_\_\_ m

The golfer returns the ball to its original position in the sandpit. He wants the ball to land at X but this time with a **smaller** horizontal velocity than in **Figure 5**.

Figure 6

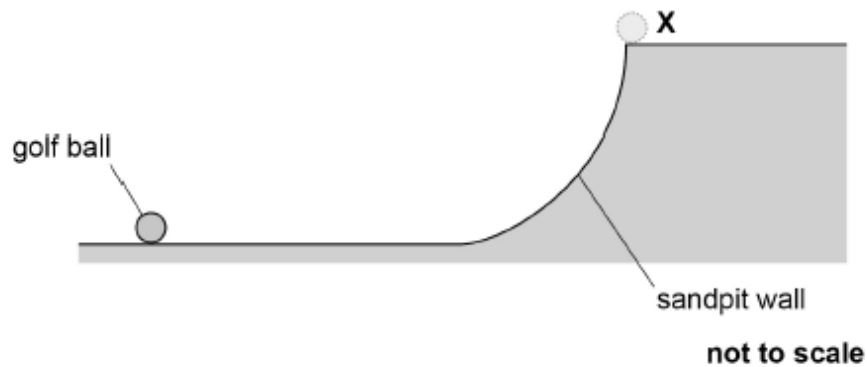

0 3 . 5 Sketch on **Figure 6** a possible trajectory for the ball.

[1 mark]

0 3 . 6 Explain your reason for selecting this trajectory.

[2 marks]

0 2 . 1 **Figure 1** shows the spacecraft of total mass 610 kg entering the atmosphere at a speed of  $5.5 \text{ km s}^{-1}$ .

Calculate the kinetic energy of the spacecraft as it enters the atmosphere.  
Give your answer to an appropriate number of significant figures.

[3 marks]

kinetic energy = \_\_\_\_\_ J

0 2 . 2 A parachute opens during the spacecraft's descent through the atmosphere.

**Figure 2** shows the parachute-spacecraft system, with the open parachute displacing the atmospheric gas. This causes the system to decelerate.

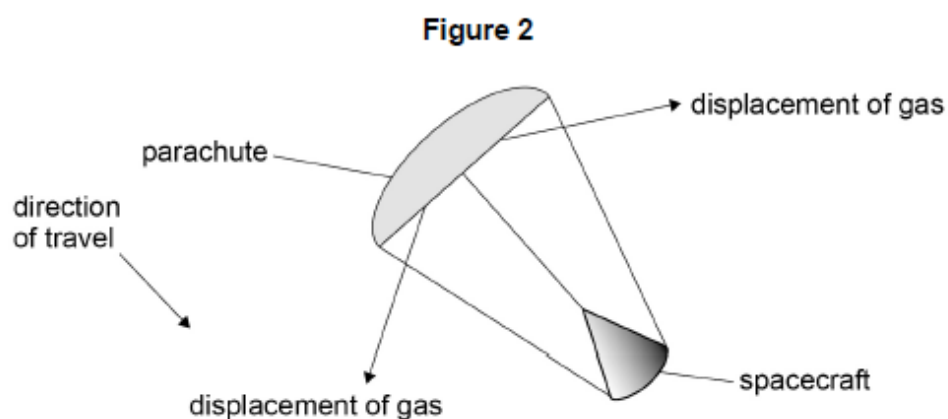

Explain, with reference to Newton's laws of motion, why displacing the atmospheric gas causes a force on the system **and** why this force causes the system to decelerate.

[4 marks]

- 0 2 . 3 As the parachute–spacecraft system decelerates, it falls through a vertical distance of 49 m and loses  $2.2 \times 10^5$  J of kinetic energy.  
During this time,  $3.3 \times 10^5$  J of energy is transferred from the system to the atmosphere.  
The total mass of the system is 610 kg.

Calculate the acceleration due to gravity as it falls through this distance.

[3 marks]

acceleration due to gravity = \_\_\_\_\_  $\text{m s}^{-2}$

- 0 2 . 4 Dust from the surface of Mars can enter the atmosphere. This increases the density of the atmosphere significantly.

Deduce how an increase in dust content will affect the deceleration of the system.

[3 marks]

- 0 5 A cell has an emf of 1.5 V and an internal resistance of  $0.65 \Omega$ .  
The cell is connected to a resistor **R**.

- 0 5 . 1 State what is meant by an emf of 1.5 V.

[2 marks]

- 0 5 . 2 The current in the circuit is 0.31 A.

Show that the total power output of the cell is approximately 0.47 W.

[1 mark]

0 5 . 3 Calculate the energy dissipated per second in resistor **R**.

[2 marks]

energy dissipated per second = \_\_\_\_\_  $\text{J s}^{-1}$

0 5 . 4 The cell stores 14 kJ of energy when it is fully charged. The cell's emf and internal resistance are constant as the cell is discharged.

Calculate the maximum time during which the fully-charged cell can deliver energy to resistor **R**.

[2 marks]

maximum time = \_\_\_\_\_ s

- 0 5 . 5** A student uses two cells, each of emf 1.5 V and internal resistance  $0.65 \Omega$ , to operate a lamp. The circuit is shown in **Figure 7**.

**Figure 7**

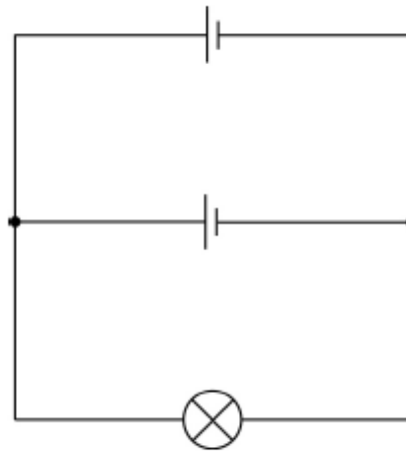

The lamp is rated at 1.3 V, 0.80 W.

Deduce whether this circuit provides the lamp with 0.80 W of power at a potential difference (pd) of 1.3 V.

Assume that the resistance of the lamp is constant.

**[4 marks]**

- 0 5 . 6** The lamp operates at normal brightness across a pd range of 1.3 V to 1.5 V.

State and explain how more of these cells can be added to the circuit to make the lamp light at normal brightness for a longer time.

No further calculations are required.

**[3 marks]**



**2** **1** A car's engine produces a useful output power of  $6.5 \times 10^4 \text{ W}$

The car of mass  $950 \text{ kg}$  is moving up a hill at a steady speed.  
The slope of the hill is  $12^\circ$  to the horizontal. Resistive forces on the car are negligible.

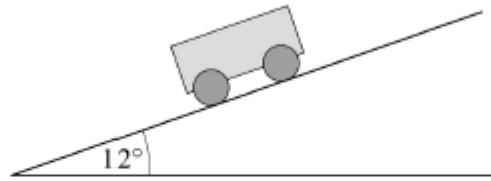

What is the steady speed of the car?

[1 mark]

A  $7.0 \text{ m s}^{-1}$

B  $12 \text{ m s}^{-1}$

C  $34 \text{ m s}^{-1}$

D  $68 \text{ m s}^{-1}$

**3** **1** A power of  $100 \text{ kW}$  at a potential difference of  $10 \text{ kV}$  is transmitted to a load resistor through cables of total resistance  $5.0 \Omega$ .

What is the power loss in the cables?

[1 mark]

A  $50 \text{ W}$

B  $0.5 \text{ kW}$

C  $100 \text{ kW}$

D  $20 \text{ MW}$

3 2

Resistors **X** and **Y** are connected in series with a 6.0 V battery of negligible internal resistance.

**X** has resistance  $R$  and **Y** has resistance  $\frac{R}{2}$ .

A voltmeter of resistance  $R$  is connected across **Y**.

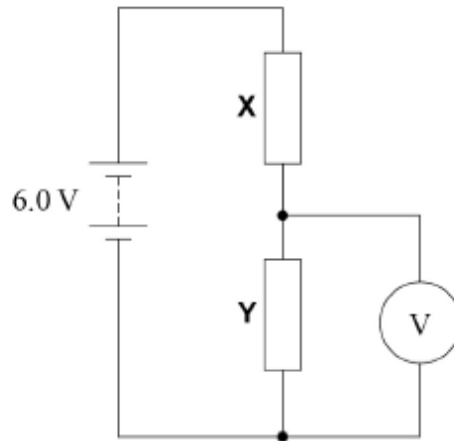

What is the reading on the voltmeter?

[1 mark]

A 0.0 V

B 1.5 V

C 3.0 V

D 4.5 V

3 4

In the circuit shown, a potential difference of 3.0 V is applied across **XY**.

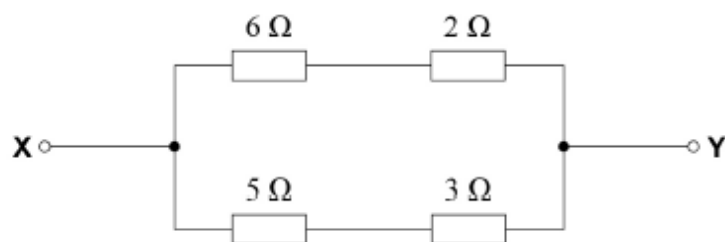

What is the current in the 5 Ω resistor?

[1 mark]

A 0.38 A

B 0.60 A

C 0.75 A

D 2.7 A

1 8

An object is in equilibrium when acted on by three coplanar forces.

Which free-body diagram is correct?

Each diagram is drawn to scale.

[1 mark]

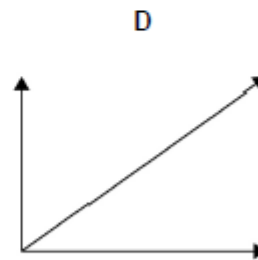
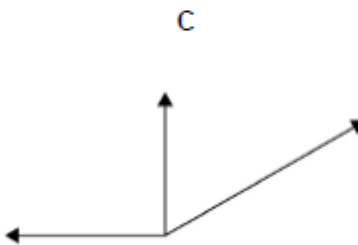
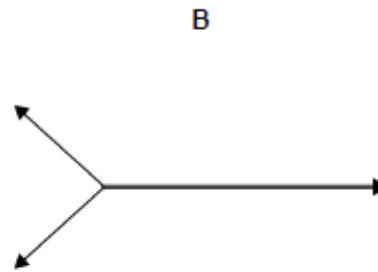
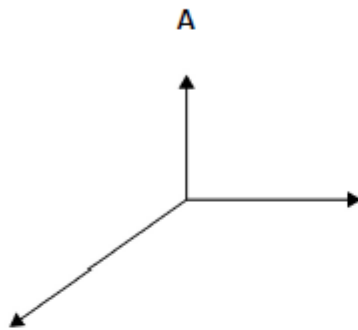

A

B

C

D

1 9

Which quantity is represented by the area under a force–time graph?

[1 mark]

A average power

B elastic strain energy stored

C momentum change

D work done

2 2 A girl is bouncing on a trampoline.

Assuming that air resistance is negligible, her acceleration

[1 mark]

- A is zero when she is at maximum height.
- B is constant when she is in the air.
- C changes direction as she rises and then falls.
- D is maximum just before she lands on the trampoline.

2 0 A bird sits on a uniform rod suspended from vertical wires P and Q.

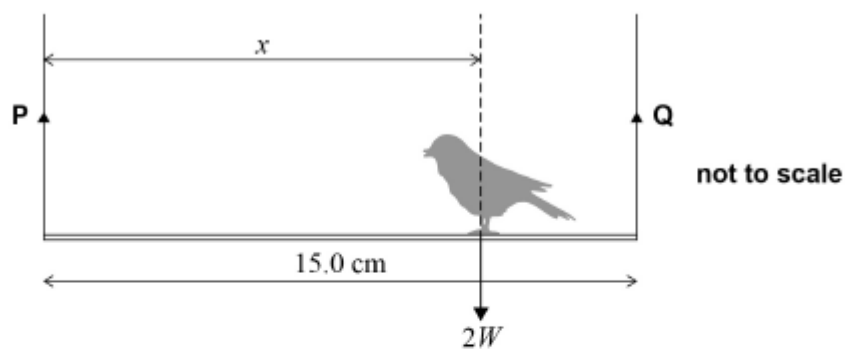

The rod has a weight  $W$  and is 15.0 cm long.  
The weight of the bird is  $2W$  and acts at a distance  $x$  from P.

What is the value of  $x$  when the tension in P is half the tension in Q?

[1 mark]

- A 7.50 cm
- B 10.0 cm
- C 11.3 cm
- D 15.0 cm