



Additional Assessment Materials
Summer 2021

Pearson Edexcel GCE in Mathematics
8MA0_22 (Public release version)

Resource Set 2: Topic 7
Kinematics

Pearson: helping people progress, everywhere

Pearson aspires to be the world's leading learning company. Our aim is to help everyone progress in their lives through education. We believe in every kind of learning, for all kinds of people, wherever they are in the world. We've been involved in education for over 150 years, and by working across 70 countries, in 100 languages, we have built an international reputation for our commitment to high standards and raising achievement through innovation in education. Find out more about how we can help you and your students at: www.pearson.com/uk

Additional Assessment Materials, Summer 2021

All the material in this publication is copyright

© Pearson Education Ltd 2021

General guidance to Additional Assessment Materials for use in 2021

Context

- Additional Assessment Materials are being produced for GCSE, AS and A levels (with the exception of Art and Design).
- The Additional Assessment Materials presented in this booklet are an optional part of the range of evidence teachers may use when deciding on a candidate's grade.
- 2021 Additional Assessment Materials have been drawn from previous examination materials, namely past papers.
- Additional Assessment Materials have come from past papers both published (those materials available publicly) and unpublished (those currently under padlock to our centres) presented in a different format to allow teachers to adapt them for use with candidate.

Purpose

- The purpose of this resource to provide qualification-specific sets/groups of questions covering the knowledge, skills and understanding relevant to this Pearson qualification.
- This document should be used in conjunction with the mapping guidance which will map content and/or skills covered within each set of questions.
- These materials are only intended to support the summer 2021 series.

1.

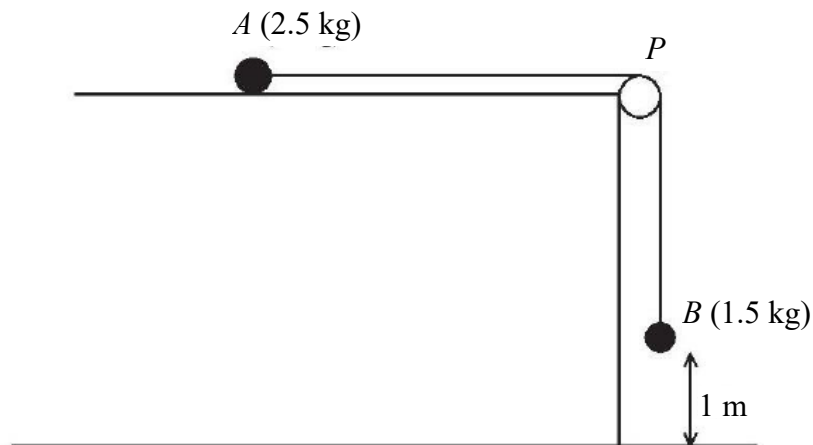

Figure 2

A small ball A of mass 2.5 kg is held at rest on a rough horizontal table.

The ball is attached to one end of a string.

The string passes over a pulley P which is fixed at the edge of the table. The other end of the string is attached to a small ball B of mass 1.5 kg hanging freely, vertically below P and with B at a height of 1 m above the horizontal floor.

The system is released from rest, with the string taut, as shown in Figure 2.

The resistance to the motion of A from the rough table is modelled as having constant magnitude 12.7 N . Ball B reaches the floor before ball A reaches the pulley.

The balls are modelled as particles, the string is modelled as being light and inextensible and the pulley is modelled as being small and smooth.

(a) (i) Write down an equation of motion for A .

(ii) Write down an equation of motion for B .

(4)

(b) Hence find the acceleration of B .

(2)

(c) Using the model, find the time it takes, from release, for B to reach the floor.

(2)

It was found that it actually took 2.3 seconds for ball B to reach the floor.

(d) Using this information,

- (i) comment on the appropriateness of using the model to find the time it takes ball B to reach the floor, justifying your answer.
- (ii) suggest one improvement that could be made in the model.

(2)

(Total for Question 1 is 10 marks)

2. A particle P moves along a straight line such that at time t seconds, $t \geq 0$, after leaving the point O on the line, the velocity, $v \text{ m s}^{-1}$, of P is modelled as

$$v = (7 - 2t)(t + 2)$$

- (a) Find the value of t at the instant when P stops accelerating. (4)
- (b) Find the distance of P from O at the instant when P changes its direction of motion. (5)

In this question, solutions relying on calculator technology are not acceptable

(Total for Question 2 is 9 marks)

3. A particle, P , moves along a straight line such that at time t seconds, $t \geq 0$, the velocity of P , $v \text{ m s}^{-1}$, is modelled as

$$v = 12 + 4t - t^2$$

Find

- (a) the magnitude of the acceleration of P when P is at instantaneous rest, (5)
- (b) the distance travelled by P in the interval $0 \leq t \leq 3$ (3)

(Total for Question 3 is 8 marks)

4. A particle, P , moves along the x -axis. At time t seconds, $t \geq 0$, the displacement, x metres, of P from the origin O , is given by $x = \frac{1}{2}t^2(t^2 - 2t + 1)$.

(a) Find the times when P is instantaneously at rest. (5)

(b) Find the total distance travelled by P in the time interval $0 \leq t \leq 2$. (3)

(c) Show that P will never move along the negative x -axis. (2)

(Total for Question 4 is 10 marks)
